

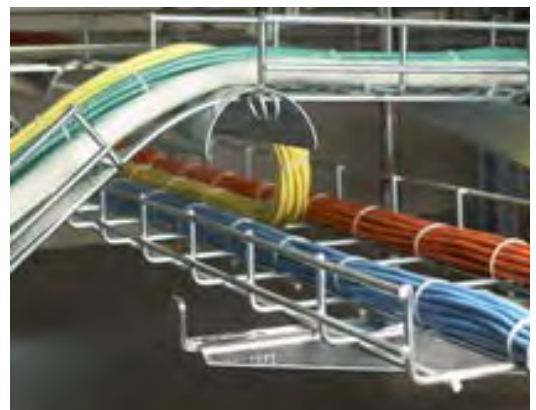

Wire Trays / Mesh Trays Defem®





Wire Trays / Mesh Trays

Defem[®]

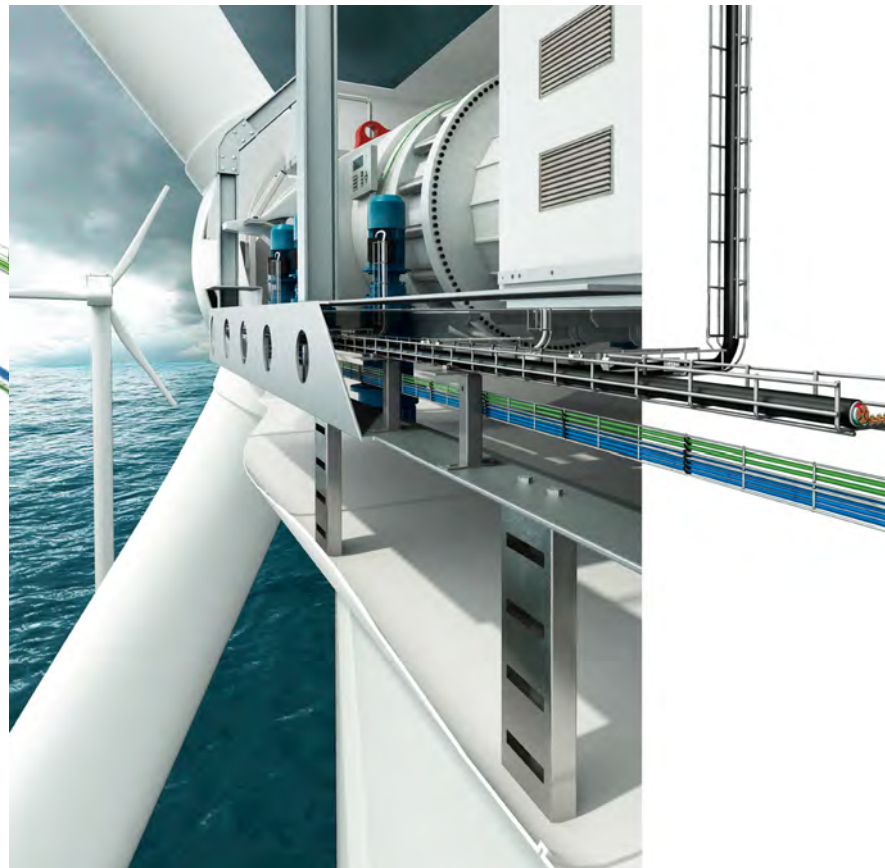
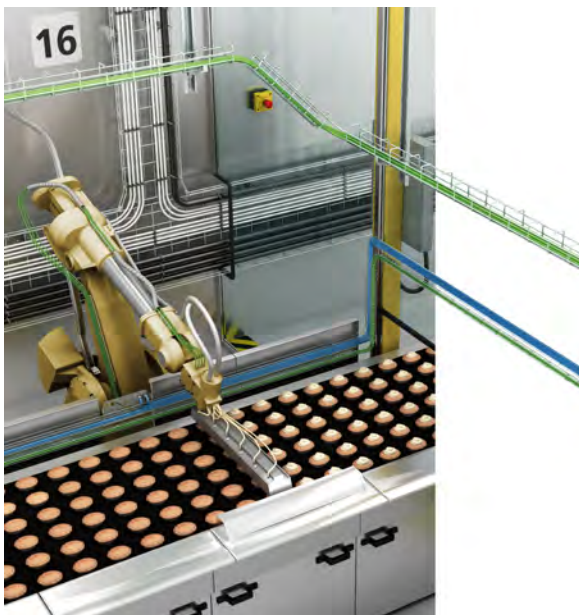
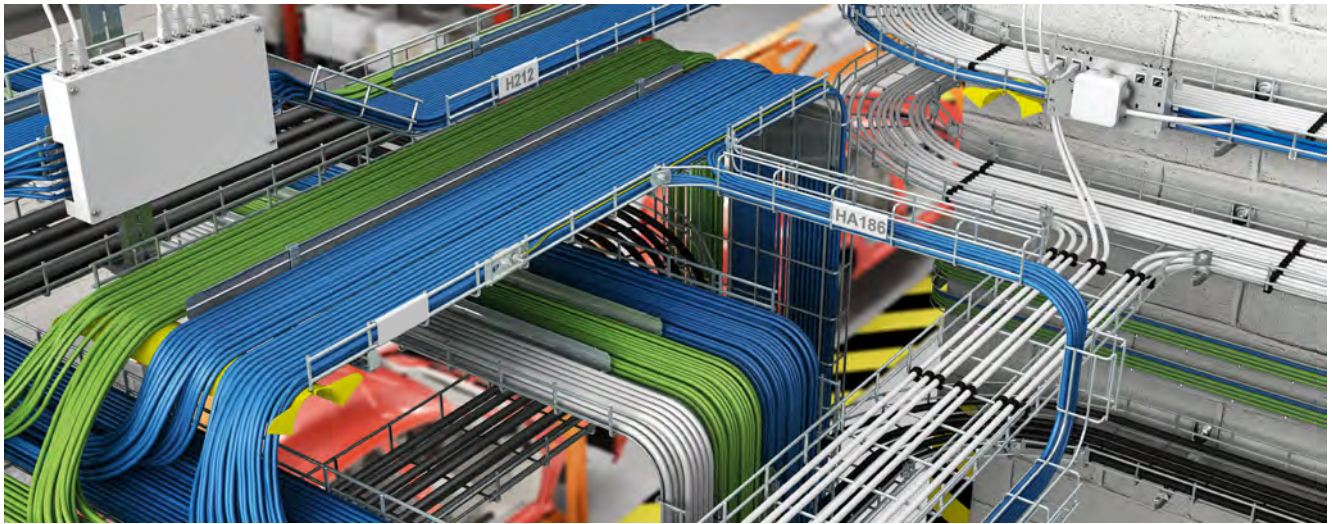

Product Overview

Wire Trays

Page 267-274

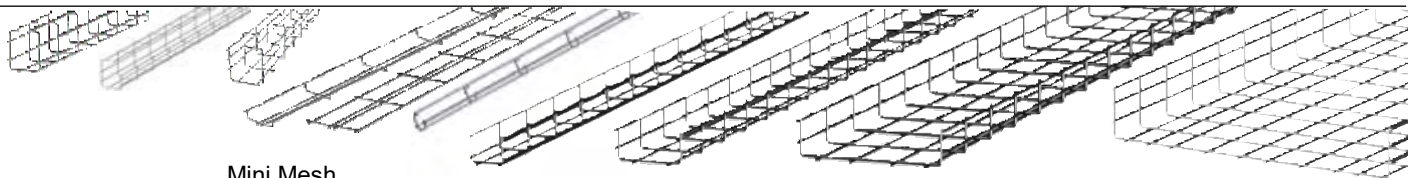

Wiretray C, G, Z

Mini Mesh
B30-U, B30-I, B30-D

Wire Trays 53/45, Wire Trays 75/55, Wire Trays 120-622/60

Wire Trays 120-622/110

Fittings

Page 274-278



Fitting B1



Fitting B2



Fitting B3



Joining set B52



Bolt and nut B13

Mountings

Page 279-285



Pendant B12L



Pendant B12



Joining Fitting B24



Extension B19

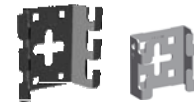

Bracket B4, B4 Mini



Angled Fitting B27

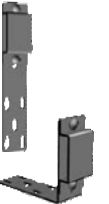

Combi Fitting B21

Combi Fitting B21 90°



Ceiling Fitting B23



Bracket B9



Support Hook B35



Conveyor Bracket B17



Support B33



Side Support B10

Mountings/Threaded Rod

Page 285-289



Threaded Rod B41



Flange Nut B43



Thread Lock B50



Distance Nut B42



Beam Clamp B49



Ceiling Clamp B48



Ceiling Fitting Universal B46



Ceiling Fitting Flexible B47



Support Hook B39

Accessories

Page 290-303



Radius Limiter B67



Radius Limiter B34



Accessories Holder B5, - B5 mini



Bend Plate B31



Clip B8

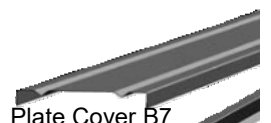

Plate Cover B7



Side radius limiter B11



Velcro B51



Cable roller B25



Mounting coupler B20



Spacer B22



Plate Holder B38



Safety Cap B32



Earth Connection Clamp B18

Tele-Channel B6/50

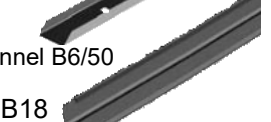

Separating Plate B36



Ident. Tag B40



Marking Clip B44



Cable Clips B16



AS-I-Clips B14



Fixing Plate B15

Separating Plate B26

Tools

Page 304



Bolt Cutter B28



Spanner B45



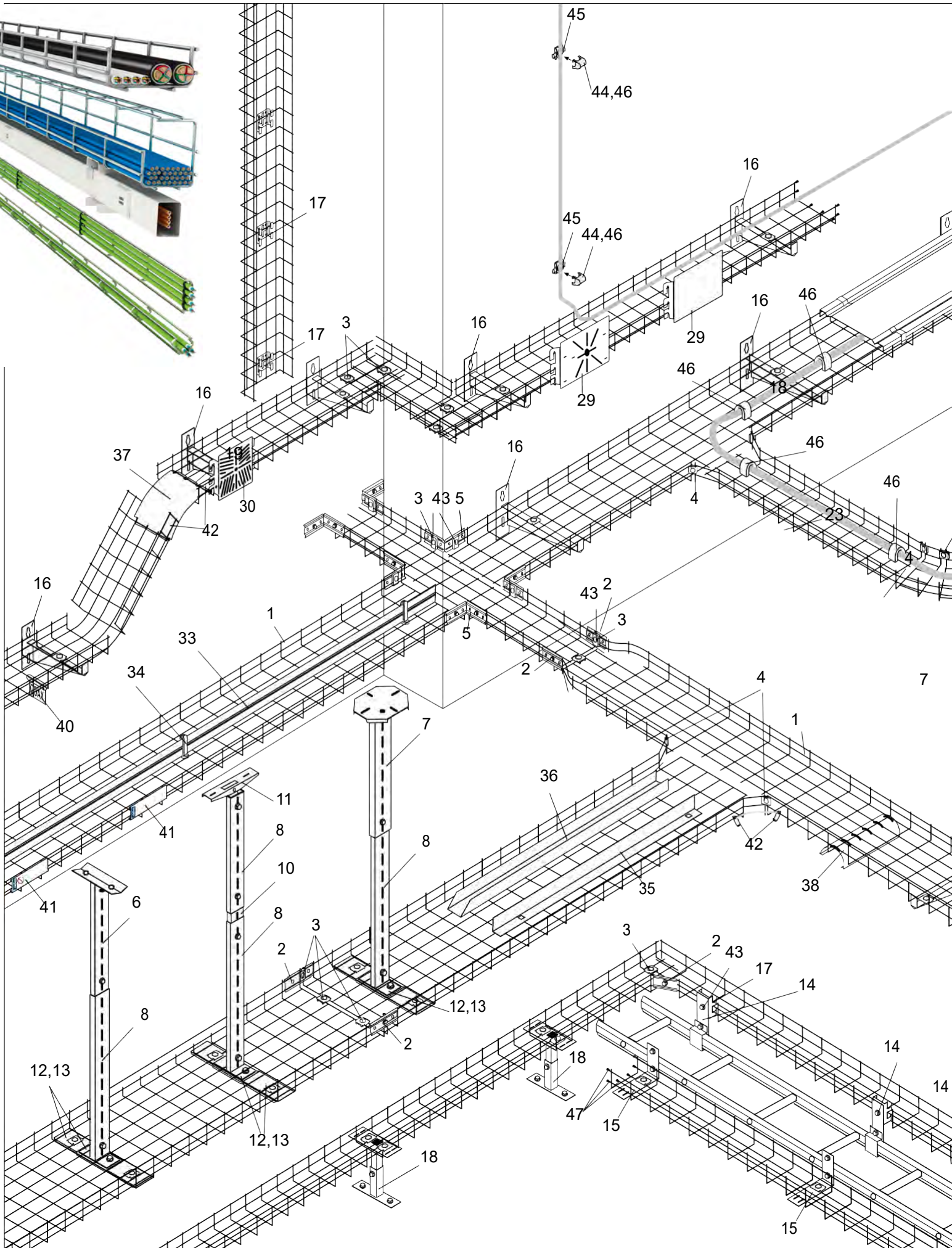

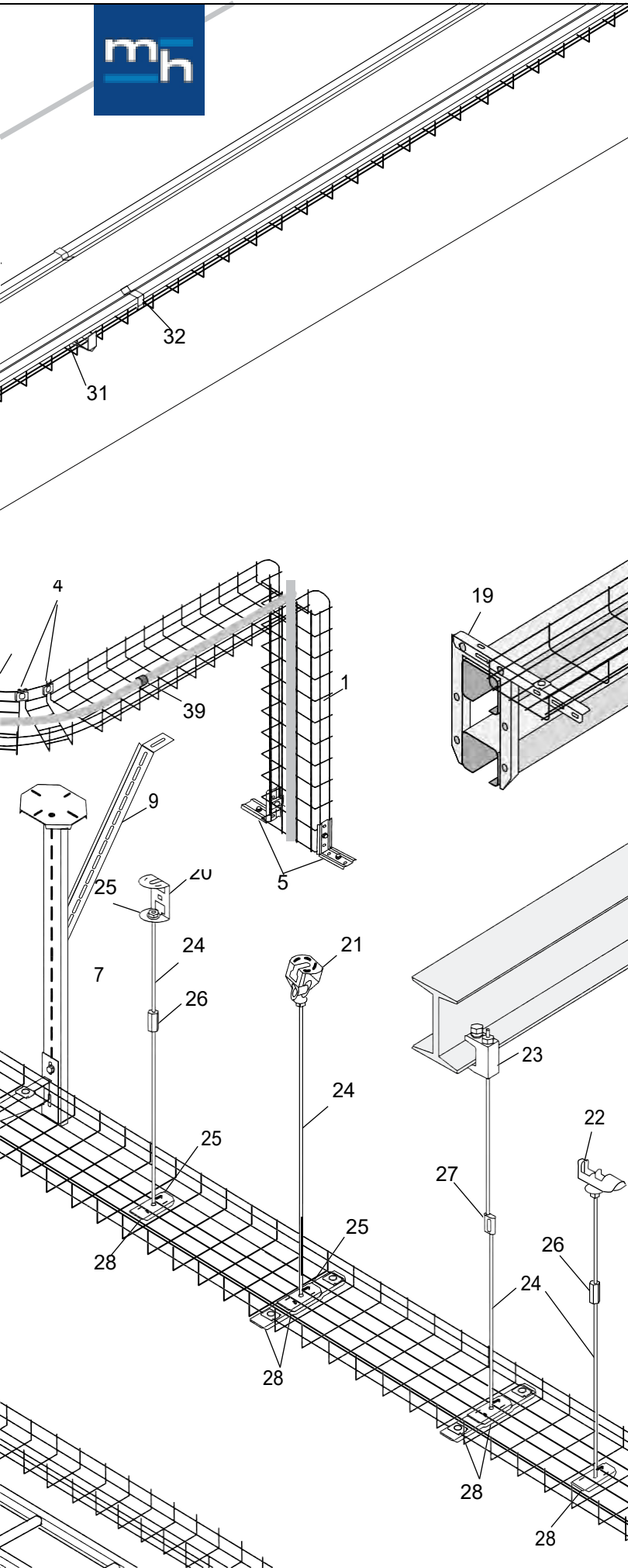

	Page
1 Wire Trays	267-269
Wire Trays C,G,Z	270-272
Mini Mesh B30-D,-U,-I	273-274
2 Fitting B1	274
3 Fitting B2	275
4 Fitting B3	276
5 Angled Fitting B27	277
6 Pendant B12L	281
7 Pendant B12	281
8 Extension B19	282
9 Side Support B10	283
10 Joining Fitting B24	283
11 Ceiling Fitting B23	282
12 SupportHook B35/120-220, 320-422	284
13 Support Hook B35/422-622	285
14 Combi Fitting B21	294
15 Combi Fitting B21 90°	294
16 Bracket B9	280
17 Bracket B4, B4 mini	279
18 Support B33	295
19 Conveyor Bracket B17	296
20 Ceiling Fitting Universal B46	285
21 Ceiling Fitting Flexible B47	286
22 Ceiling Clamp B48	286
23 Beam Clamp B49	289
24 Threaded Rod B41	287
25 Flange Nut B43	287
26 Distance Nut B42	288
27 Thread Lock B50	288
28 Support Hook B39	289
29 Accessories Holder B5	290
30 Accessories Holder B5 mini	290
31 Plate Cover B7	291
32 Clip B8	291
33 Separating Plate B36	292
34 Plate Holder B38	292
35 Separating Plate B26	293
36 Tele-Channel B6	293
37 Bend Plate B31	298
38 Radius Limiter B11, B34, B67	298-299
39 Velcro B51	302
40 Identification Tag B40	303
41 Marking Clip B44	303
42 Earth Connection Clamp B18	296
43 Bolt and Nut B13	278
44 AS-I clips B14	300
45 Fixing Plate B15	301
46 Cable Clips B16	301
47 Safety Cap B32	297

List of reports on test carried out by the Swedish Testing and Research Institute (SP)

Wire Trays

SP 94 H	14050
SP 91 M	10856
SP 97 H	50333 a
SP 97 H	50333 b
P 007525	

SP 9920616	Compl.
Surface treatment	SP 94 M
	51439 and -A

Brackets

SP 91 M	10579
SP 91 M	10530

Vibration

SP 94 F	20903
---------	-------

Other tests

Measurements of resistance value from different combinations of Wire Tray DEFEM® and Defem U-bars.
Report no. LNKM 036 99.

Test made by

Telia, Sweden

Tests with Category 5 and 6 cables, in room temperature and in climatic room with different loads, up to 43 layers, about 250 mm. Report no. Danak-19J0698/Delta K311126.

Delta Institute, Denmark

Tests with fibre patch cord with 2 mm thickness. In room temperature with different loads corresponding to layers of patch cord up to 300 mm.

Schenker/Telia Sonera, Nässjö

Test Concerning equipotential bonding, (DIN VDE 0100). Test

TÜV, Germany

Concerning fire resistance according to norm E90. Test

IBMB, Germany

Concerning fire resistance according to EN 1363-1.

Pavus, Czech Rep.

Wire Tray DEFEM® as conductor of equipotential bonding according to norm IEC 61537, 11:1.

SP, Sweden

Wire Tray DEFEM® is approved for use in USA and Canada according to Underwriters Laboratories - UL, E-80034.

UL, USA



Resistance/Conductivity in mΩ/5 m (incl. Joining fitting).

Tray	Electro-galv. mΩ/5 m	Hot Dip galvanized mΩ/5 m	Stainless Steel mΩ/5 m
622/110	1,28	1,89	9,41
622/60	1,50	2,23	10,81
522/110	1,50	2,23	10,81
522/60	2,27	2,51	12,01
422/110	2,27	2,51	12,01
422/60	2,90	3,35	16,67
320/110	2,90	3,35	16,67
320/60	4,20	4,46	22,17
220/110	4,20	4,46	22,17
220/60	5,60	5,52	26,20
120/110	5,60	5,52	26,20
120/60	7,10	6,58	34,79
75x5/55	6,70	9,98	50,98
75x4/55	6,85	10,12	51,10
53/45	7,13	11,05	51,88

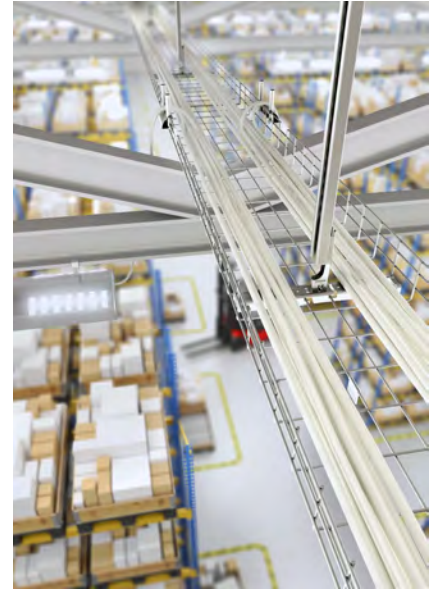

Wire trays 53-622 mm

Height	45, 55, 60 and 110 mm
Length	2500 mm
Width	53, 75, 120, 220, 320, 422, 522, 622
Pre-galvanized	
Hot dip galvanized	X
Powder coated white	Produced to order
Electro-galvanized	X
Stainless steel AISI 316L	X

Up to 5x faster installation

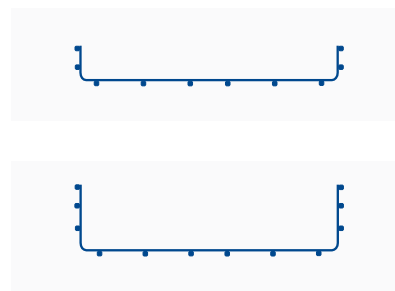

Wire trays C, G, Z and Mini Mesh trays

Height	6, 15, 24, 75, 80, 95, 100, 130, 150 mm
Length	2000, 2500 mm
Width	30, 46, 60, 75, 120, 220 mm
Pre-galvanized	
Hot dip galvanized	X
Powder coated white	Produced to order
Electro-galvanized	X
Stainless steel AISI 316L	X

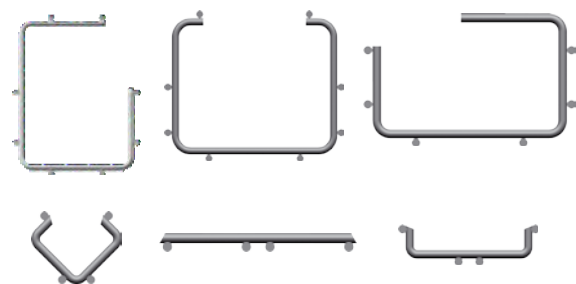



Wire Trays

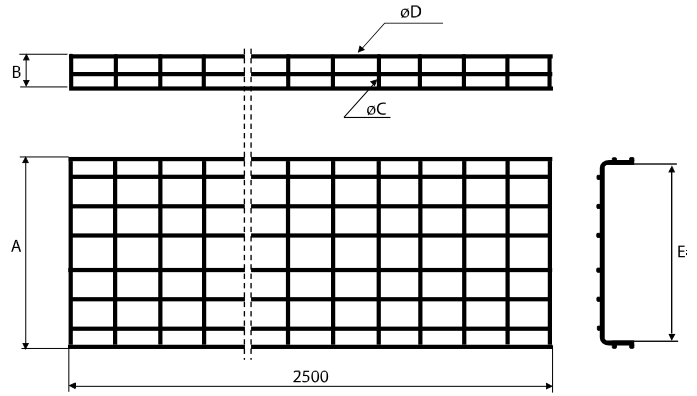
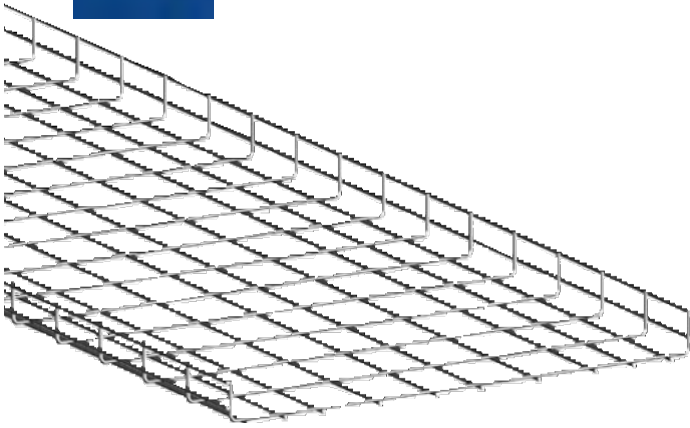

	A mm	B mm	C mm	D mm	E mm	Electro-galv. Part. No	Weight kg	Hot dip galv. Part. No	Weight kg	Stainl. steel AISI316L Part. No	Weight kg
Wire Tray 53/45	53	45	4	4	37	11 491 13	1,75	11 492 13	1,85	11 493 13	1,76
Wire Tray 75x4/55	75	55	4	4	59	11 491 00	1,87	11 492 00	2,04	11 493 00	1,90
Wire Tray 75x5/55	75	55	5	5	55	11 491 10	2,90	11 492 10	3,06	11 493 10	2,97
Wire Tray 120/60	120	60	5	5	100	11 491 01	3,11	11 492 01	3,40	11 493 01	3,18
Wire Tray 220/60	220	60	5	5	200	11 491 02	4,30	11 492 02	4,53	11 493 02	4,37
Wire Tray 320/60	320	60	5	5	300	11 491 03	5,46	11 492 03	5,85	11 493 03	5,55
Wire Tray 422/60	422	60	5	6	400	11 491 14	7,57	11 492 14	8,17	11 493 14	7,72
Wire Tray 522/60	522	60	5	6	500	11 491 15	8,95	11 492 15	9,49	11 493 15	9,22
Wire Tray 622/60	622	60	5	6	600	11 491 16	10,40	11 492 16	11,06	11 493 16	10,75

Loading capacity

For evenly loaded tray (maximum load).

Conforms to Swedish standard EL-AMA 98 for heavy cable ladder. (SBD.212).

Free location of joints between supports.

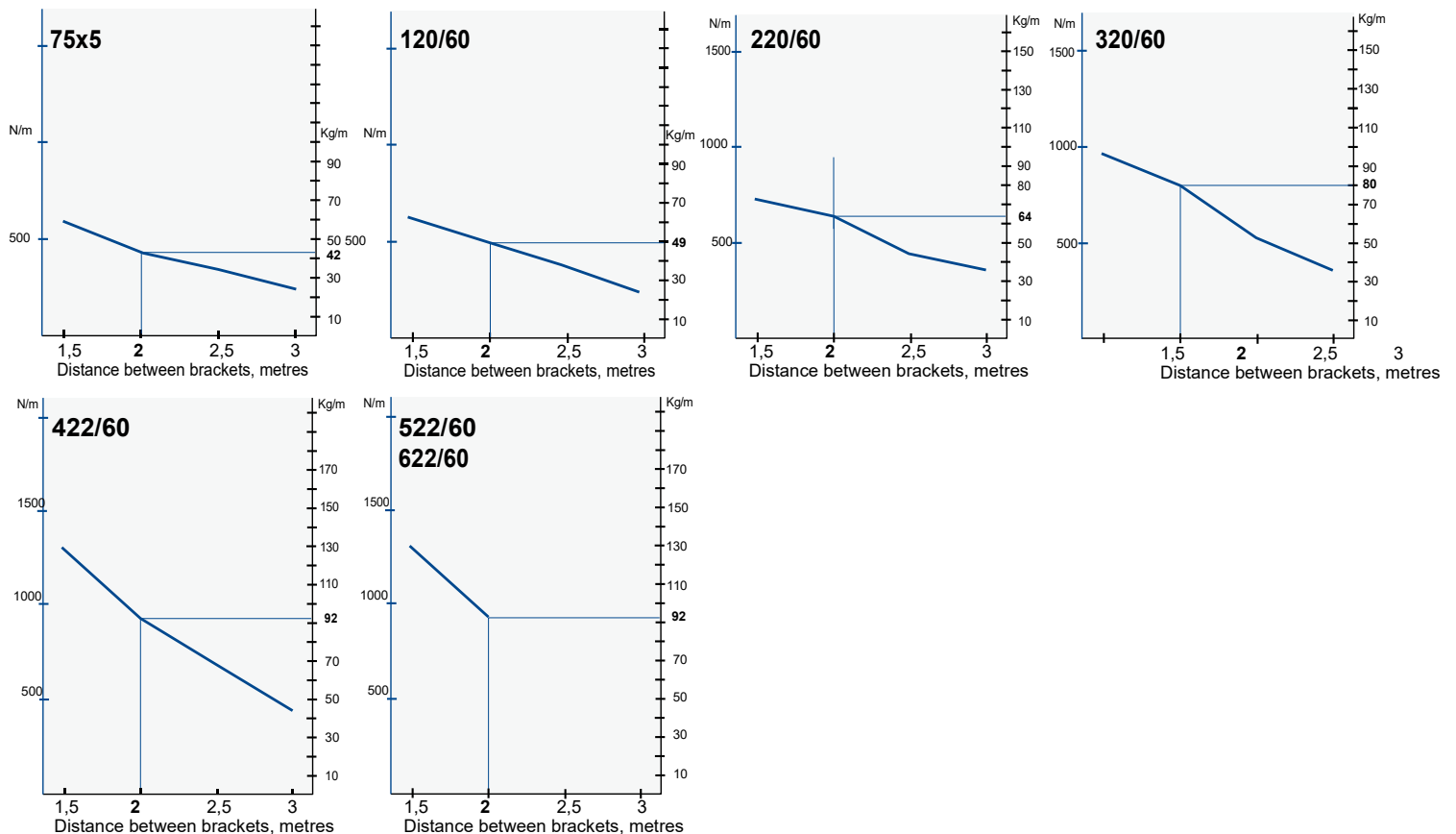

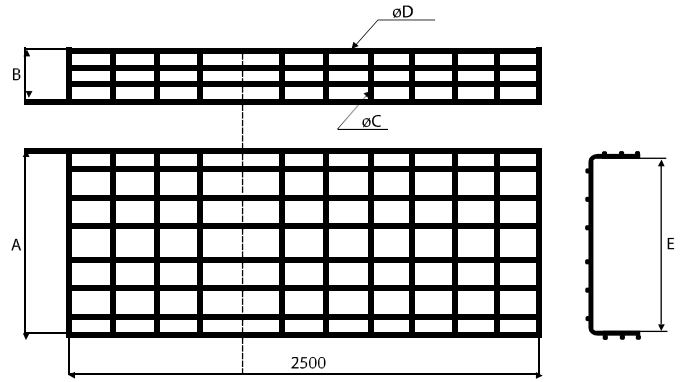
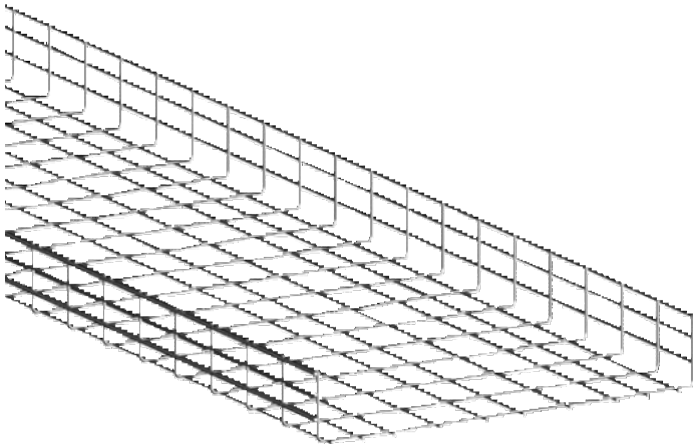

	A mm	B mm	C mm	D mm	E st	Electro-galv. Part. No	Weight kg	Hot dip galv. Part. No	Weight kg	Stainl. steel AISI316L Part. No	Weight kg
Wire Tray 120/110	120	110	5	5	100	11 491 04	4,30	11 492 04	4,53	11 493 04	4,43
Wire Tray 220/110	220	110	5	5	200	11 491 05	5,46	11 492 05	5,84	11 493 05	5,62
Wire Tray 320/110	320	110	5	5	300	11 491 06	6,63	11 492 06	7,09	11 493 06	6,83
Wire Tray 422/110	422	110	5	6	400	11 491 07	8,95	11 492 07	9,49	11 493 07	9,22
Wire Tray 522/110	522	110	5	6	500	11 491 08	10,44	11 492 08	11,06	11 493 08	10,75
Wire Tray 622/110	622	110	5	6	600	11 491 09	10,83	11 492 09	11,48	11 493 09	11,16

Loading capacity

For evenly loaded tray (maximum load).

Conforms to Swedish standard EL-AMA 98 for heavy cable ladder. (SBD.212).

Free location of joints between supports.

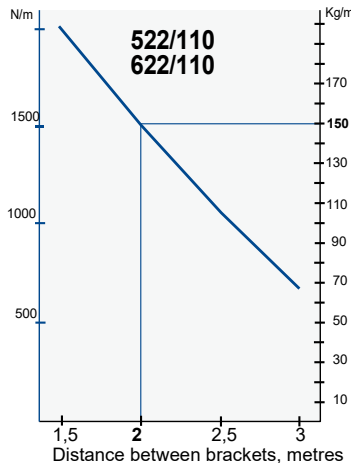
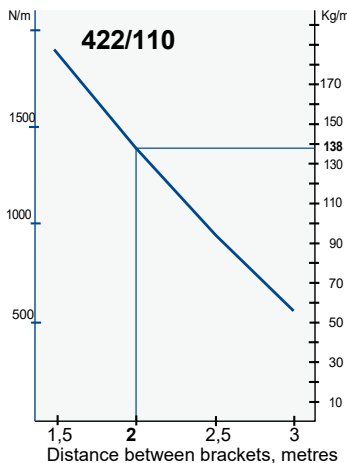
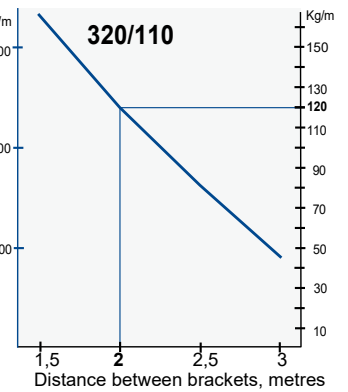
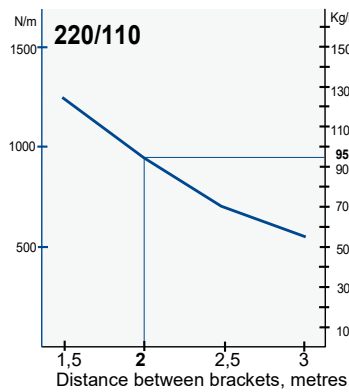
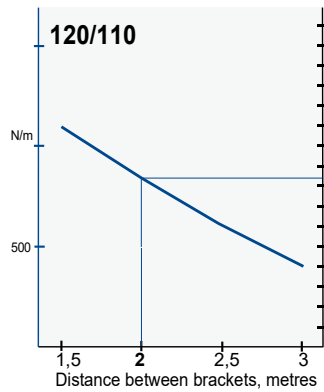

C-Wire tray

For use where mounting with long support distances (up to 4 metres) are needed.

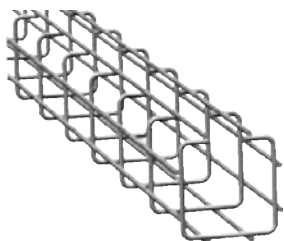

Wire Ø 4 mm

C-Wire tray 75x75

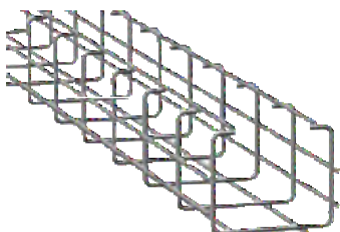
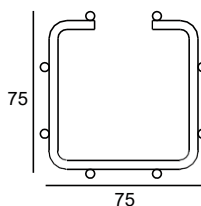

Wire Ø 5 mm

C-Wire tray 120x100

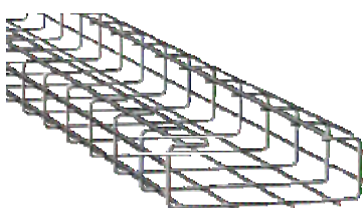
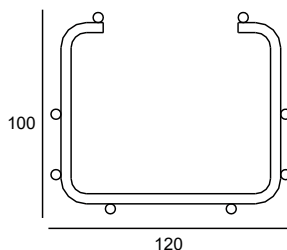

Wire Ø 5 mm

C-Wire tray 220x80

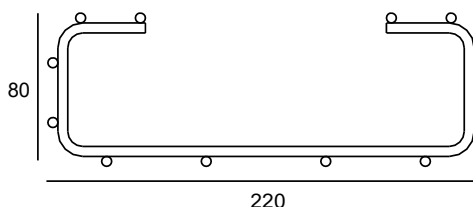

	Dim. mm	Electro-galv. Part. No	Weight kg	Hot dip galv. Part. No	Weight kg	Stainl. steel AISI316L Part. No	Weight kg
C-Wire tray 75x75	2500x75x75	11 49132	2,58	11 492 32	2,78	11 493 32	2,53
C-Wire tray 120x100	2500x120x100	11 491 33	4,37	11 492 33	4,72	11 493 33	4,29
C-Wire tray 220x80	2500x220x80	11 49134	6,34	11 492 34	6,85	11 493 34	6,23

Use and installation

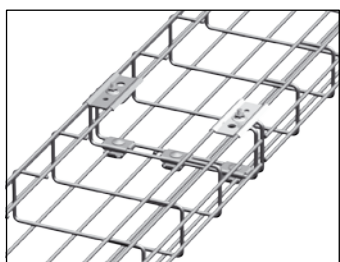

Joining of two C-Wire trays 220x80.

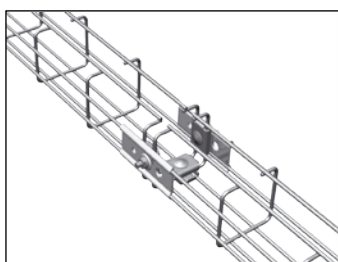

Joining of two C-Wire trays 75x75.

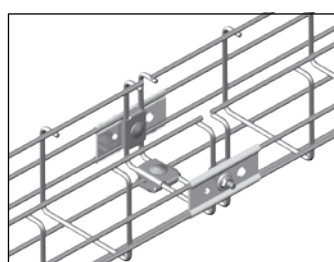

Joining of two C-Wire trays 120x100.



G-Wire tray

For installation in ceilings, onto walls, under desks and mounting on cable ladders.

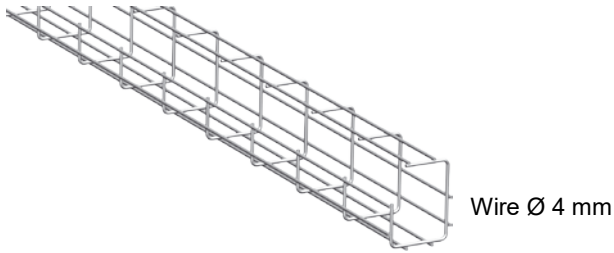

G-Wire tray 75x95

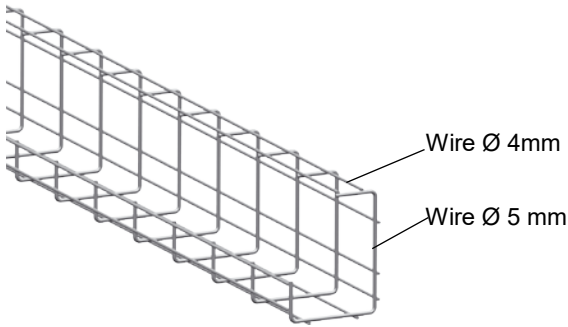
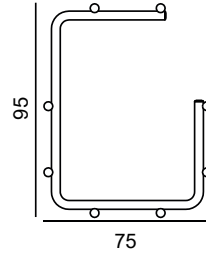

G-Wire tray 120x150

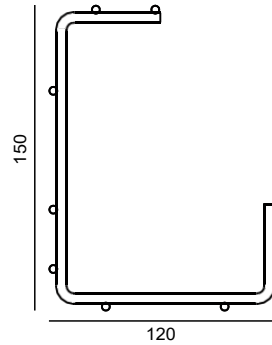

	Dim. mm	Electro-galv. Part No	Weight kg	Hot dip galv. Part No	Weight kg	Stainl. steel AISI316L Part No	Weight kg
G-Wire tray 75x95	2500x75x95	11 491 38	2,56	11 492 38	2,88	11 493 38	2,60
G-Wire tray 120x150	2500x120x150	11 491 39	3,56	11 492 39	3,92	11 493 39	3,50

Use and installation

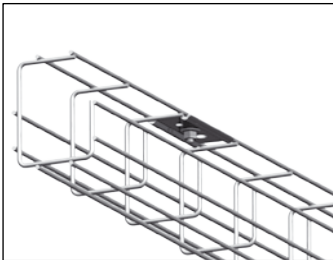

For mounting in ceilings, under desks etc. Fitting B1 is used.

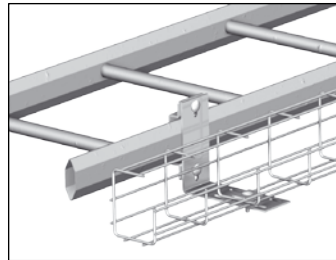

G-Wire tray mounted on cable ladder, Combi fitting B21 90° is used.

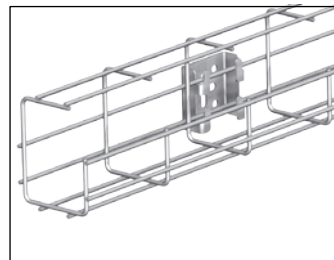

Bracket B4 can also be used for mounting onto floor, wall or ceiling.

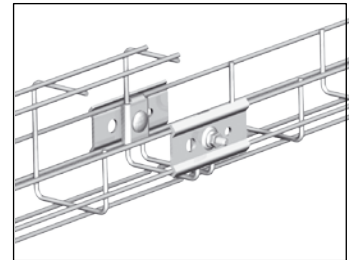

Fittings B1 and B2 are used for joining the wire trays.



Z-Wire tray

For environments where regular and thorough cleaning is required.

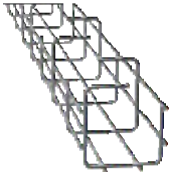

Z-Wire tray 75x75

Wire Ø 5 mm

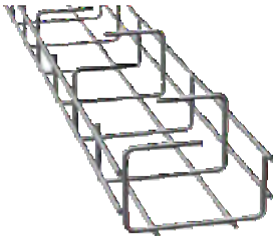
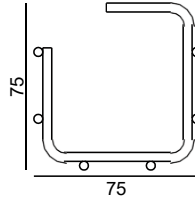

Z-Wire tray 120x80

Wire Ø 5 mm

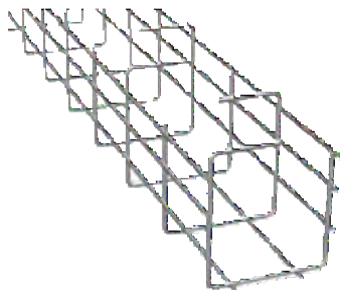
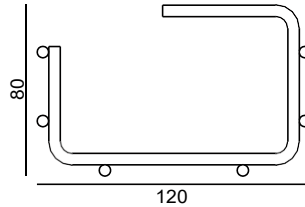

Z-Wire tray 120x130

Wire Ø 5 mm

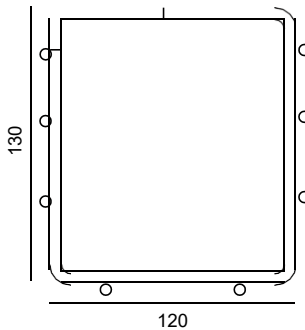

	Dim. mm	Stainl. steel AISI316L Part No	Weight kg
Z-Wire tray 75x75	2500x75x75	11 493 40	2,01
Z-Wire tray 120x80	2500x120x80	11 493 41	3,51
Z-Wire tray 120x130	2500x120x130	11 493 42	4,69

Use and installation

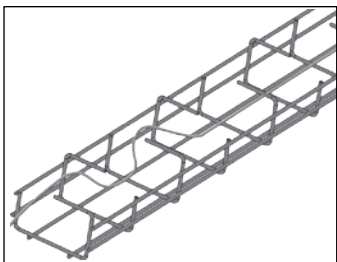

The cable is routed in a zigzag pattern inside the Z-Wire tray.

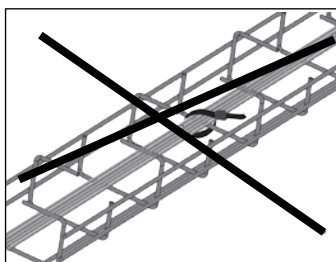

No cable ties are needed, not even in vertically mounted trays.

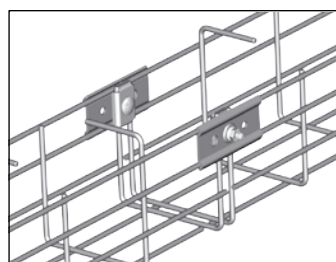

Fittings B1 and B2 are used for joining of Z-Wire trays.

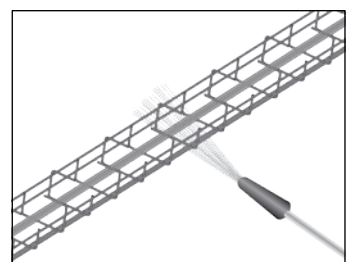

The non-bundled cables will stay in place during cleaning.



Mini Mesh B30-D

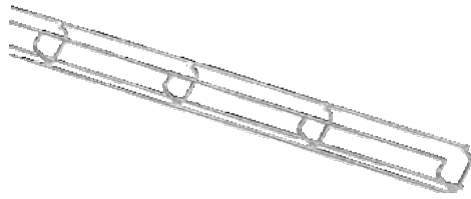

Wire Ø 3 mm

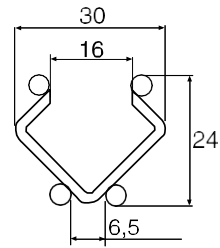

	Length mm	Electro-galv. Part No	Weight kg	Hot dip galv. Part No	Weight kg	Stainl. steel AISI316L Part No	Weight kg
Mini Mesh B30-D	2000	11 491 12	0,50	11 492 12	0,55	11 493 12	0,52

Use and installation

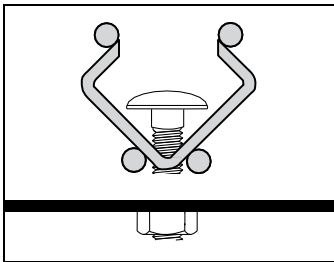

Can be mounted with Bolt and Nut B13.

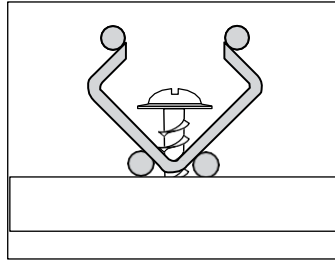

Can be mounted with suitable screw for wood, concrete etc.

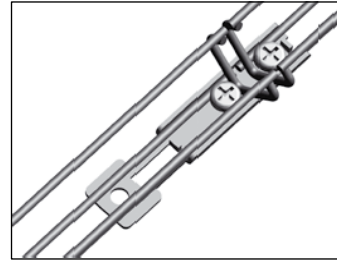

Two Mini Mesh B30-D joined with Mounting coupler B20.

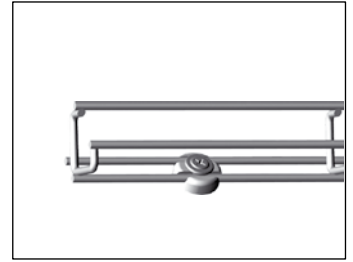

B30-D mounted onto Mounting spacer B22.

Mini Mesh B30-U

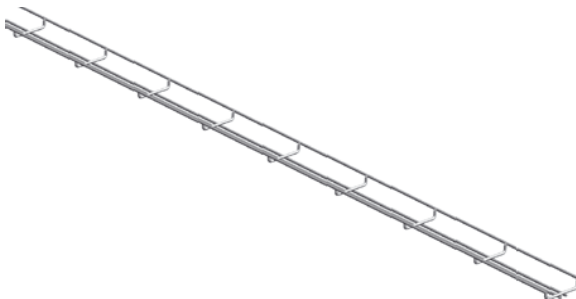

Wire Ø 3 mm

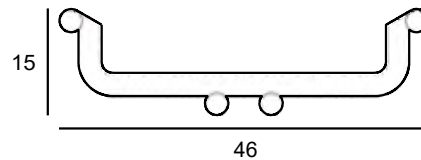

	Length mm	Electro-galv. Part No	Weight kg	Hot dip galv. Part No	Weight kg	Stainl. steel AISI316L Part No	Weight kg
Mini Mesh B30-U	2000	11 491 25	0,50	11 492 25	0,55	11 493 25	0,52

Use and installation



B30-U mounted onto Mounting spacer B22.

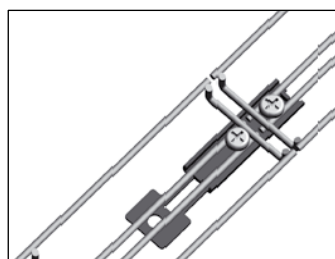

Two Mini Mesh B30-U joined with Mounting coupler B20.

Mini Mesh B30-I

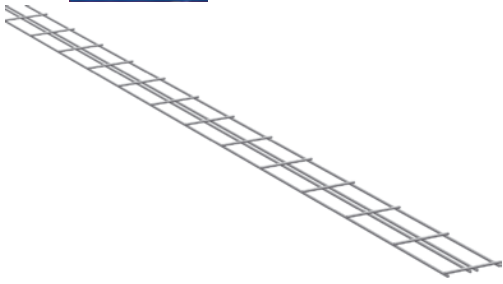

Wire Ø3mm

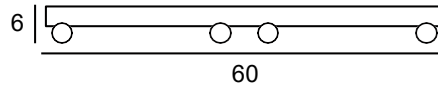

	Length mm	Electro-galv. Part No	Weight kg	Hot dip galv. Part No	Weight kg	Stainl. steel AISI316L Part No	Weight kg
Mini Mesh B30-I	2000	11 491 11	0,50	11 492 11	0,55	11 493 11	0,52

Use and installation

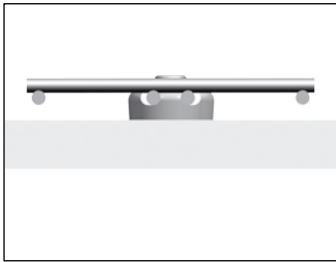

B30-I mounted onto
Mounting spacer B22.



B30-I mounted onto cable
ladder.

Fitting B1

Delivered without bolt and nut.

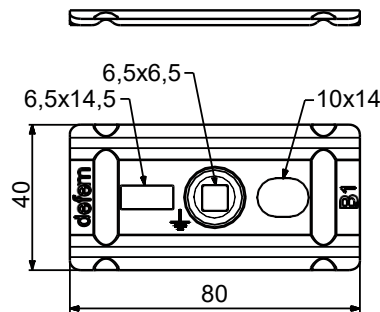

	Electro-galv. Part No	Weight kg	Hot dip galv. Part No	Weight kg	Stainl. steel AISI316L Part No	Weight kg
Fitting B1	11 491 54	0,06	11 492 54	0,07	11 493 54	0,06

Use and installation

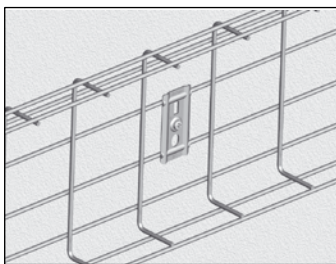

Fitting B1 can be used as a
wall bracket.

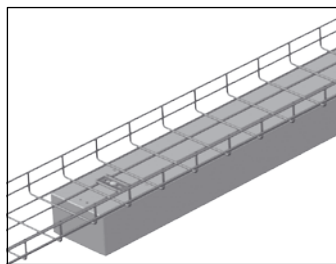

Fitting B1 can be mounted
over the centre wires as
carrier of fittings.

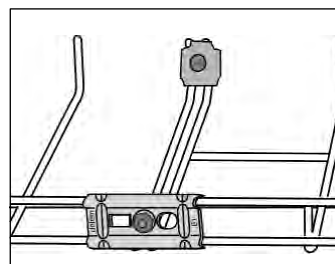

Wire tray 53 to 220 is joined
with:
2 pcs of Fitting B1
2 pcs of Fitting B2
2 pcs of Bolt and Nut B13

Fitting B2

Delivered without bolt and nut.

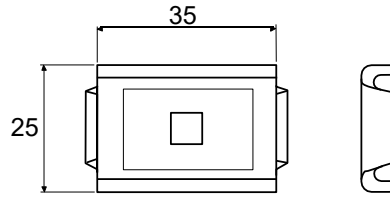

	Electro-galv. Part. No	Weight kg	Hot dip galv. Part. No	Weight kg	Stainl. steel AISI316L Part. No	Weight kg
FittingB2	11 49155	0,02	11 492 55	0,02	11 493 55	0,02

Use and installation

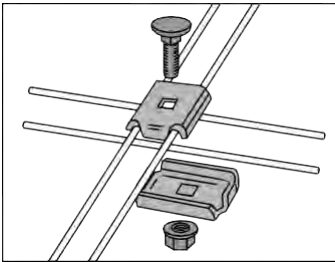

For joining in bottom of tray:
2 pcs of Fitting B2
1 pc of Bolt and Nut B13.

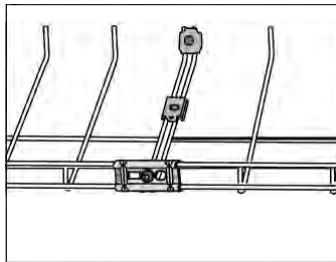

Wire tray 320 is joined with
2 pcs of Fitting B1
4 pcs of Fitting B2
3 pcs of Bolt and Nut B13

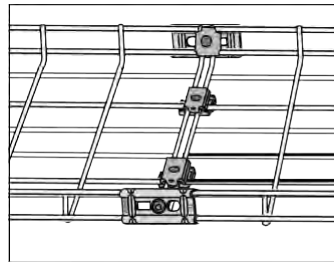

Wire tray 422 is joined with
2 pcs of Fitting B1
6 pcs of Fitting B2
4 pcs of Bolt and Nut B13

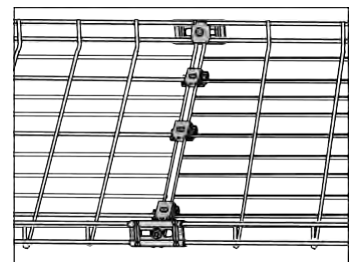

Wire tray 522 and 622 is joined with
2 pcs of Fitting B1
8 pcs of Fitting B2
5 pcs of Bolt and Nut B13

90° angling with Fitting B1 och B2

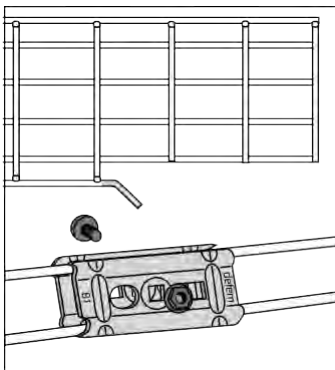

To obtain a softer inner angle,
2 Fittings B1 can be mounted
with Bolt and Nut B13.

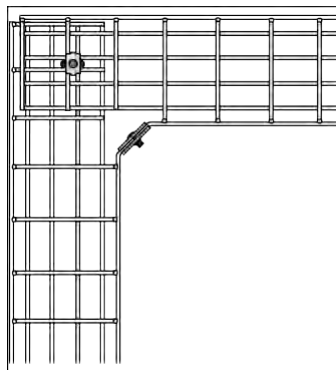

Wire tray 53 to 220 are
joined with:
2 pcs of Fitting B1
2 pcs of Fitting B2
2 pcs of Bolt and Nut B13

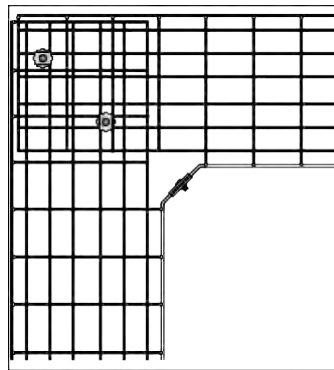

Wire tray 320 and 422 are
joined with:
2 pcs of Fitting B1
4 pcs of Fitting B2
3 pcs of Bolt and Nut B13

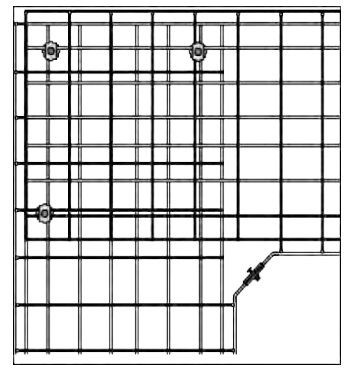

Wire tray 522 and 622 are
joined with:
2 pcs of Fitting B1
6 pcs of Fitting B2
4 pcs of Bolt and Nut B13

Fitting B3

Delivered with bolt and nut.

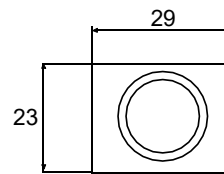
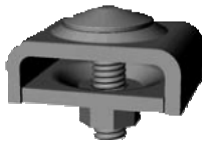

	Electro-galv. Part. No	Weight kg	Hot dip galv. Part. No	Weight kg	Stainl. steel AISI316L Part. No	Weight kg
Fitting B3	11 491 56	0,04	11 492 56	0,04	11 493 56	0,04

Use and installation

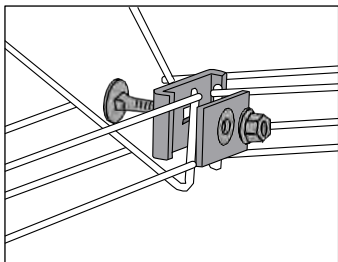

Horizontal bends are joined with Fitting B3.

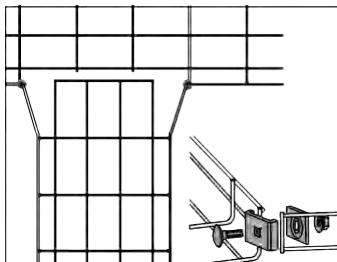

Four way and tees are joined with Fitting B3.

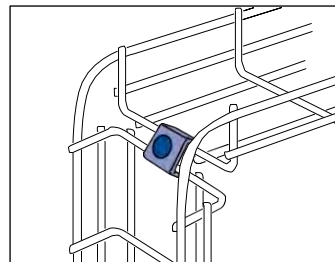

Vertical bends are joined with one or more Fitting B3, depending on wire tray width.

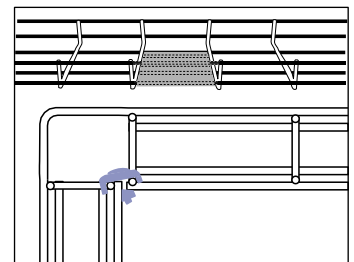

Wire tray 53 is shaped to straight 90° angle by cutting out marked 90° wires and joined with Fitting B3.

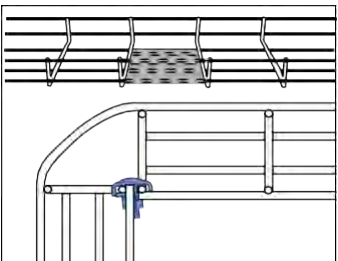

Wire tray 53 is shaped to straight 90° angle by cutting out marked wires and joined with Fitting B3.

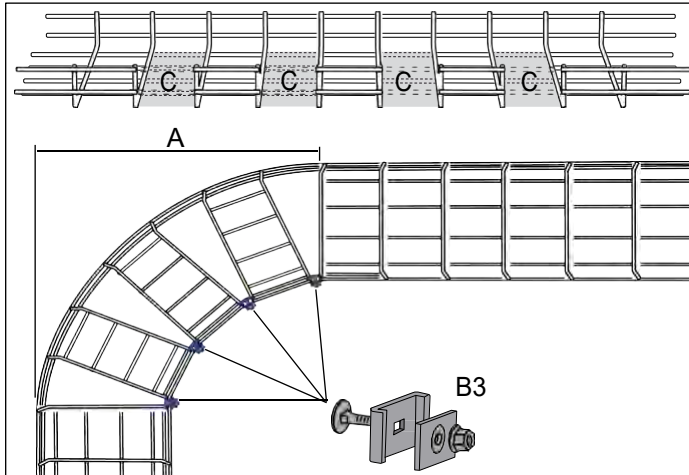

Wire tray 120-622 is shaped to straight 90° angle by cutting out every other marked wire tray section and joined with Fitting B3 according to table below.

Wire Tray	A mm	C No. of cut-out sections	Fitting B3 No.
120	300	2	2
220	550	4	4
320	820	6	6
422	1080	8	8
522	1320	10	10
622	1590	12	12

Angled fitting B27

For tees and mountings to wall, ceiling and floor etc.

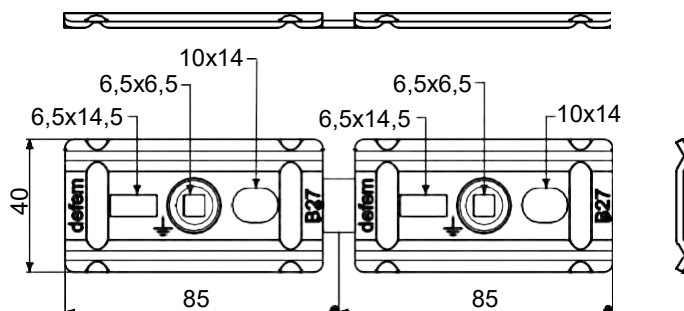

	Electro-galv. Part No	Weight kg	Hot dip galv. Part No	Weight kg	Stainl. steel AISI316L Part No	Weight kg
Angled fitting B27	11 491 69	0,13	11 492 69	0,13	11 493 69	0,13

Use and installation



For vertical branching under wire trays, all widths:
 1 pce of Angled fitting B27
 1 pce of Fitting B1
 1 pce of Fitting B2
 2 pcs of Bolt and Nut B13

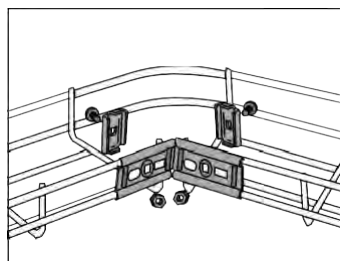

To join the bend:
 1 pce of Angled fitting B27
 2 pcs of Fitting B2
 2 pcs of Bolt and Nut B13.

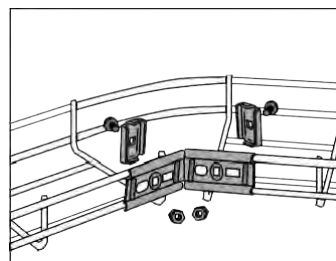

The bend can be adjusted by shaping the Angled fitting B27 to the required angle.

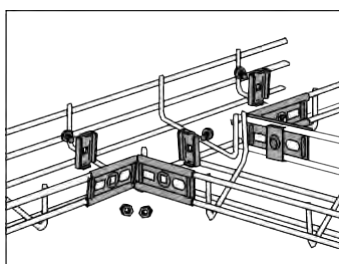

90° tee is created with:
 2 pcs of Angled fitting B27
 4 pcs of Fitting B2
 4 pcs of Bolt and Nut B13.

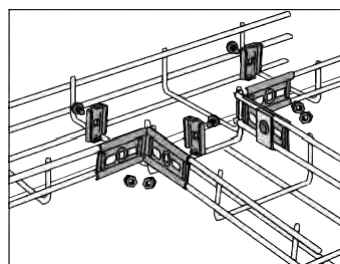

Tee with required angle is created with:
 2 pcs of Angled fitting B27
 4 pcs of Fitting B2
 4 pcs of Bolt and Nut B13.

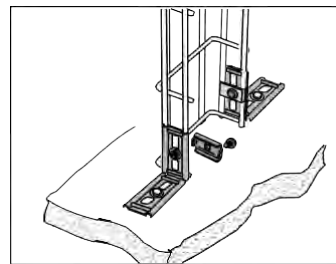

Mounting to floor/ceiling is created with:
 2 pcs of Angled fitting B27
 2 pcs of Fitting B2
 2 pcs of Bolt and Nut B13.

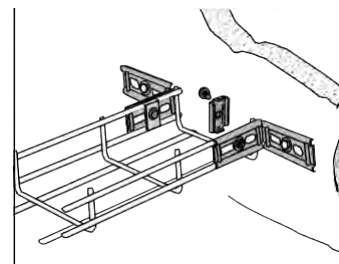

Mounting to wall is created with:
 2 pcs of Angled fitting B27
 2 pcs of Fitting B2
 2 pcs of Bolt and Nut B13.

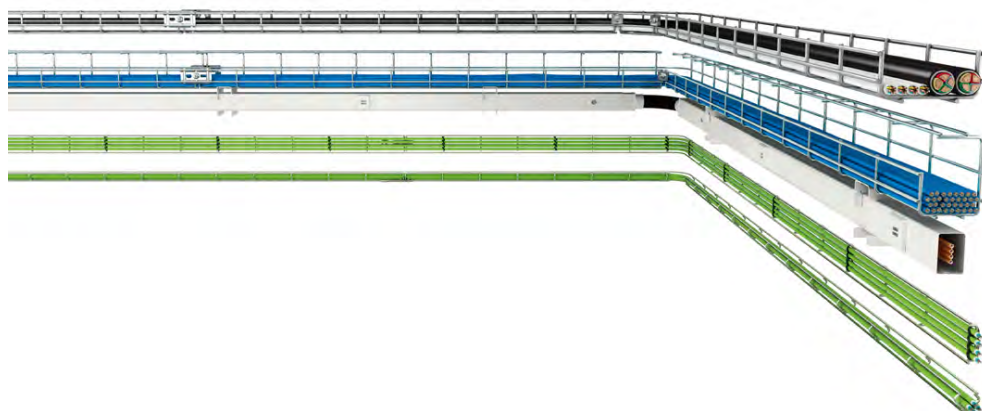

Joining set B52

Pre-assembled joining fitting that saves time (Fittings B1, B2, Bolt and Nut B13).
Used for joining of the side sections of all wire trays.

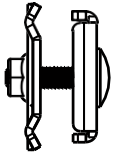
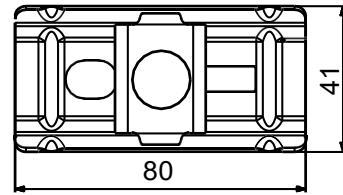
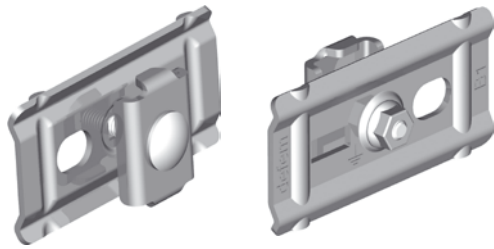

	Electro-galv. Part No	Weight kg	Hot dip galv. Part No	Weight kg	Stainl. steel AISI316L Part No	Weight kg
Joining set B52	11 491 53	0,09	11 492 53	0,10	11 493 53	0,09

Use and installation

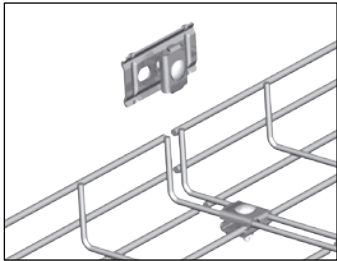

Mount Joining set B52 on the side section.

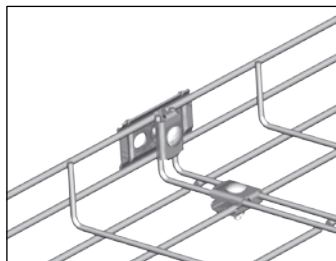

Tighten the bolt and the joining is finished.

Note! For joining of 320 mm trays and wider, extra Fittings B2 need to be mounted with Bolt and Nut B13 in the bottom of the trays.

Bolt and Nut B13

M6x25. Tensi-Lock and Flange Nut M6.

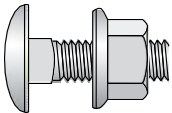

	Number/ package	Electro-galv. Part. No	Weight kg	Hot dip galv. Part. No	Weight kg	Stainl. steel AISI316L Part. No	Weight kg
Bolt and Nut B13/50+50	50 st	11 491 84	0,56	11 492 84	0,57	11 493 84	0,59
Bolt and Nut B13/250+250	250 st	11 491 85	2,82	11 492 85	2,80	11 493 85	2,90

Bracket B4/B4 mini

For mounting of Wire trays 53-622 onto wall and floor.

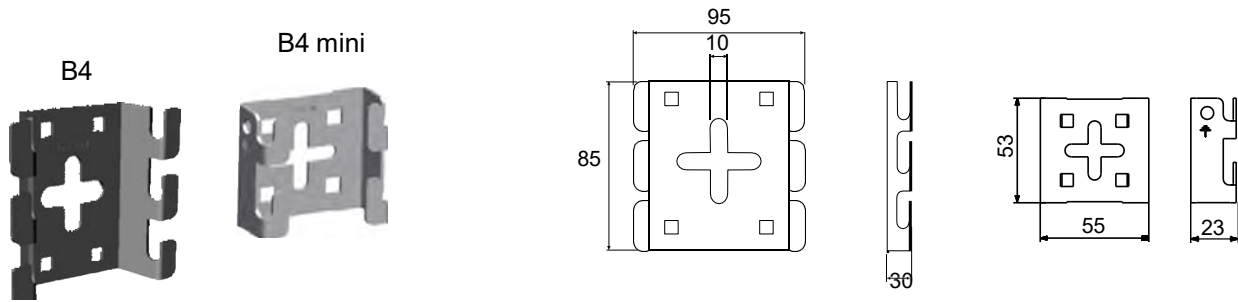

	Electro-galv. Part. No	Weight kg	Hot dip galv. Part. No	Weight kg	Stainl. steel AISI316L Part. No	Weight kg
Bracket B4	1149157	0,14	1149257	0,15	1149357	0,15
Bracket B4 mini	1149198	0,06	1149298	0,06	1149398	0,05

Use and installation B4

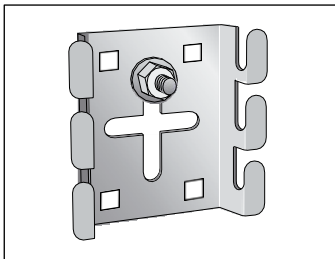

Mounted to wall/ceiling/floor with Expansion bolt in middle hole or screws in corner holes.

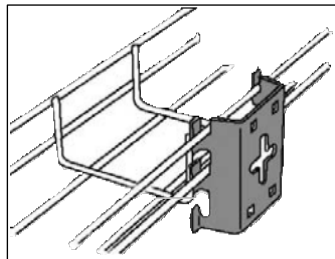

The side wires of the tray are easily hooked onto the grips of the bracket.

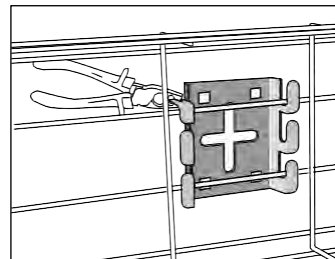

For increased stability, the B4 grips can be closed around the wires.

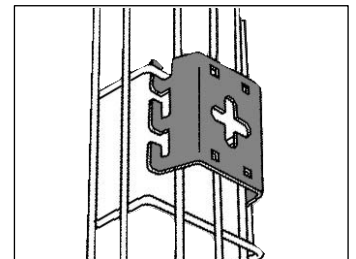

The wire tray can also be mounted vertically.

Use and installation B4 Mini

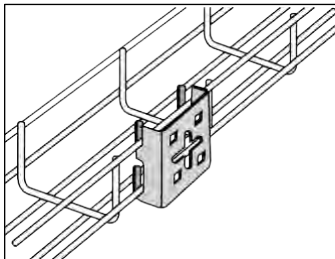

For horizontal mounting with bottom or side of tray onto the bracket grips.

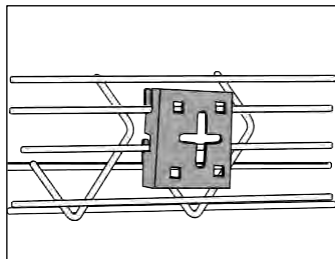

The wire tray can also be mounted with 45° angle.

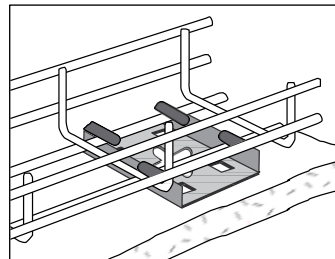

The Wire tray can also be mounted to floor.

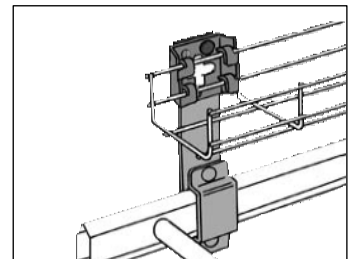

Wire trays are mounted onto Combi Fitting B21 with Bracket B4 or B4 Mini.



Bracket B9

For mounting of Wire Trays onto walls and pendants.

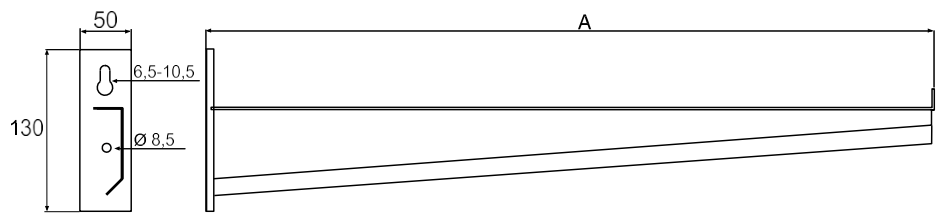
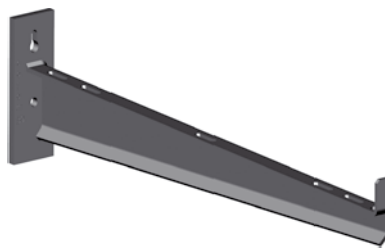
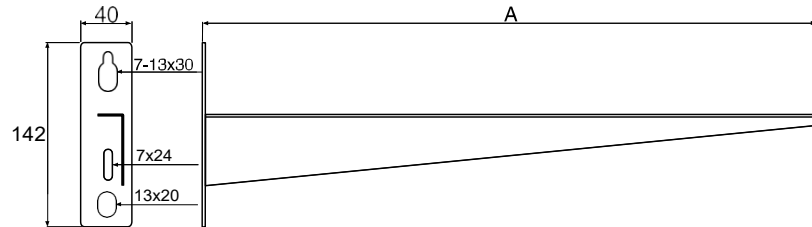
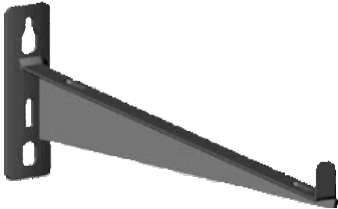
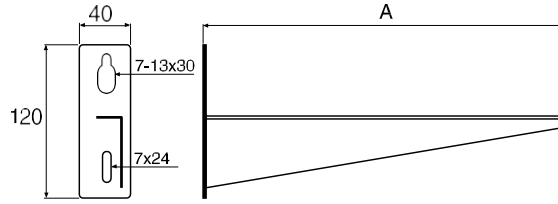
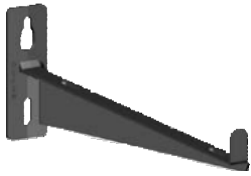

	A mm	Electro-galv. Part. No	Weight kg	Hot dip galv. Part. No	Weight kg	Stainl. steel AISI316L Part. No	Weight kg
Bracket B9/75-120	180	11 491 21	0,40	11 492 21	0,42	11 493 21	0,34
Bracket B9/220	280	11 491 22	0,52	11 492 22	0,55	11 493 22	0,46
Bracket B9/320	380	11 491 23	0,64	11 492 23	0,68	11 493 23	0,59
Bracket B9/422	480	11 491 24	0,83	11 492 24	0,86	11 493 24	0,76
Bracket B9/522	580	11 491 95	1,60	11 492 95	1,60	11 493 95	1,60

Use and installation

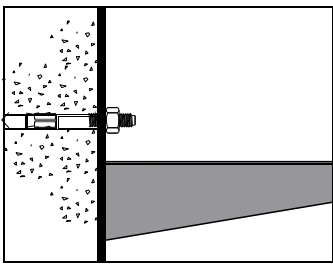

Mounting to wall with Expansion bolt M8 or M10.

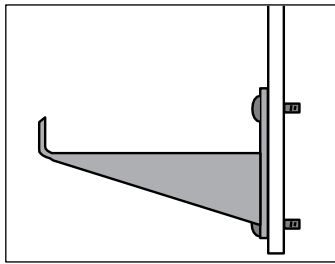

Mounting to Pendant B12L with 2 Bolt and Nut B13.

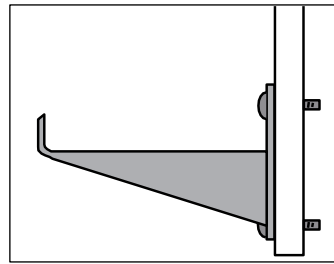

Mounting to Pendant B12 with 2 Bolt and Nut B13.

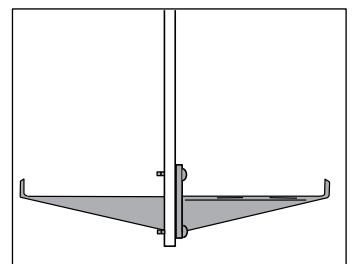

Double side mounting of Brackets onto B12 with 2 Bolt and Nut B13.

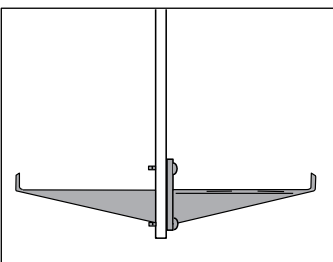

Double side mounting of Brackets onto Extension B19 with 2 Bolt and Nut B13.

Pendant B12L

For light installation. Mounted with M8/M10 bolt. Telescopic extension with B19.

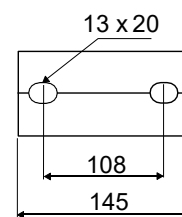
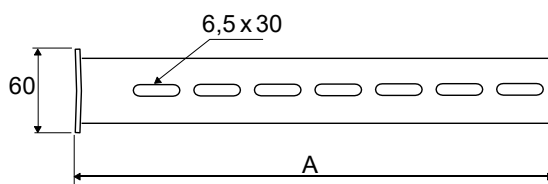
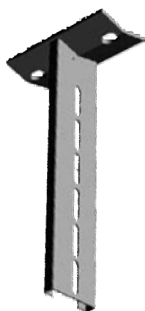

	A mm	Electro-galv. Part. No	Weight kg	Hot dip galv. Part. No	Weight kg	Stainl. steel AISI316L Part. No	Weight kg
Pendant B12L/250	250	1149136	0,65	1149236	0,69	1149336	0,61
Pendant B12L/500	500	1149146	1,00	1149246	1,05	1149346	0,97

Use and installation

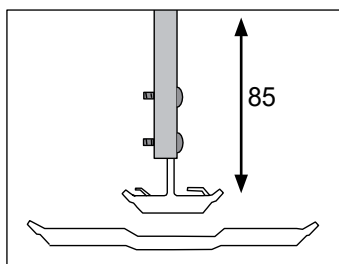

Support Hook B35 is mounted with 2 pcs Bolt and Nut B13. Adjustable in height with 85 mm.

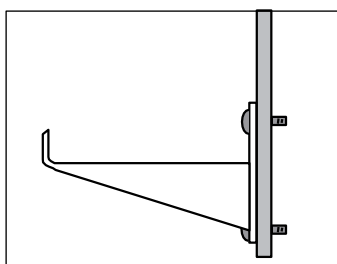

Bracket B9 is mounted with 2 pcs Bolt and Nut B13.

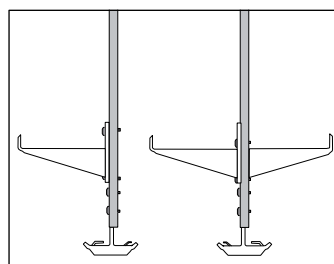

One side load only with Bracket B9/75-120
Double side mounting with Brackets B975-622.

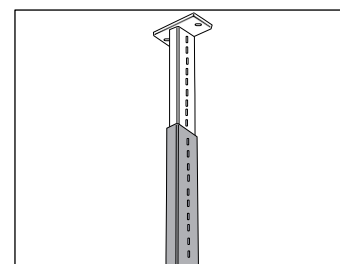

Pendant B12 is extended min 1010 max 1445 mm with Extension B19, mounted with 2 Bolt and Nut B13.

Pendant B12

For heavy installation. Mounted with M8/M10 bolt. Telescopic extension with B19.

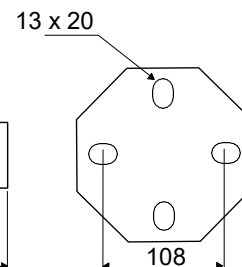
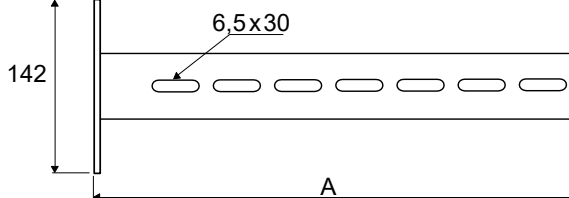
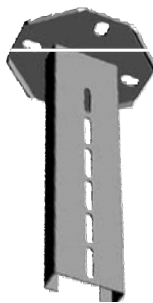

	A mm	Electro-galv. Part. No	Weight kg	Hot dip galv. Part. No	Weight kg	Stainl. steel AISI316L Part. No	Weight kg
Pendant B12/250	250	1149148	1,15	1149248	1,35	1149348	1,28
Pendant B12/500	500	1149150	1,88	1149250	1,98	1149350	2,07

Use and installation

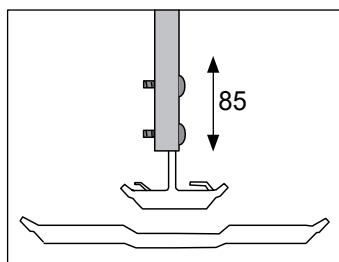

Support Hook B35 is mounted with 2 pcs Bolt and Nut B13. Adjustable in height with 85 mm.

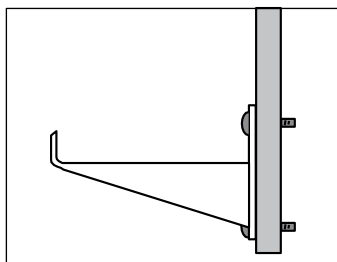

Bracket B9 is mounted with 2 pcs Bolt and Nut B13.

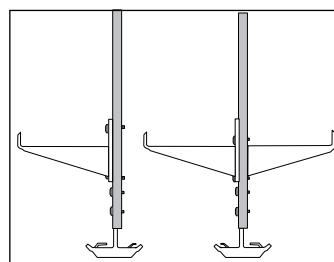

Double side mounting of Bracket widths 75-422.

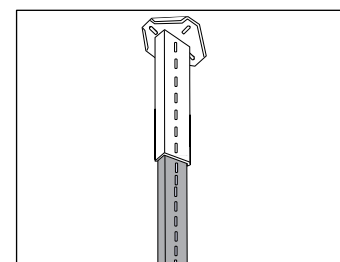

Pendant B12 is extended min 1010 max 1445 mm with Extension B19, mounted with 2 Bolt and Nut B13.

Ceiling Fitting B23

For mounting onto straight or sloping ceiling.

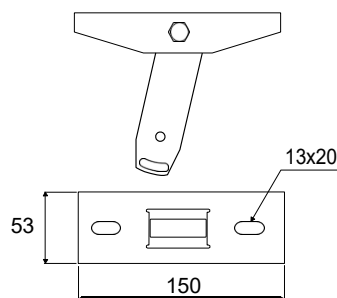

	Electro-galv. Part. No	Weight kg	Hot dip galv. Part. No	Weight kg	Stainl. steel AISI316L Part. No	Weight kg
Ceiling Fitting B23	11 491 64	0,42	11 492 64	0,44	11 493 64	0,43

Use and installation

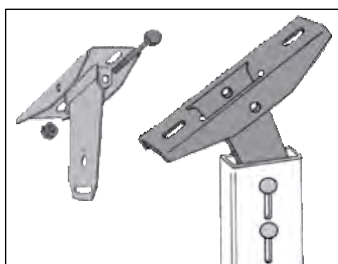

The ceiling plate of the Ceiling Fitting B23 adapts to the slope of the ceiling. Extension B19 is mounted with 2 Bolt and Nut B13.

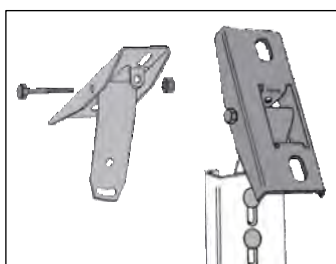

Mounting in 90° angle.

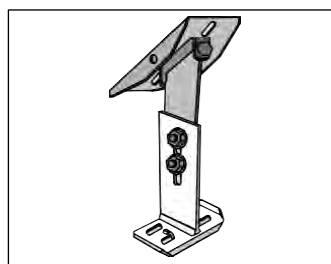

Support Hook B35 can be mounted directly onto Ceiling Fitting B23 with 2 Bolt and Nut B13.

Extension B19

For telescopic extension of Pendant B12, B12L and for mounting onto Ceiling Fitting B23.

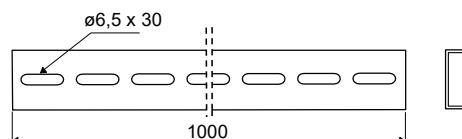

	Electro-galv. Part. No	Weight kg	Hot dip galv. Part. No	Weight kg	Stainl. steel AISI316L Part. No	Weight kg
Extension B19	11 491 61	1,70	11 492 61	1,82	11 493 61	1,71

Use and installation

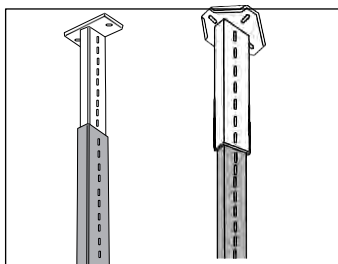

Pendant B12 and B12L is extended min 1010 max 1445 mm with Extension B19, mounted with 2 Bolt and Nut B13.

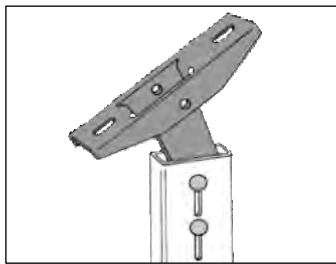

Extends the Ceiling Fitting B23 for sloping and straight ceiling, mounted with Bolt and Nut B13.

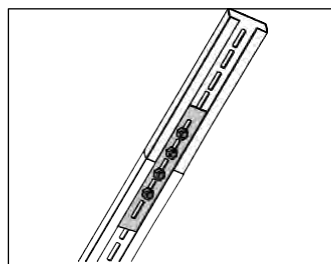

Joining Fitting B24

Joining Fitting for Extension B19 and mounting onto Ceiling Fitting B23.

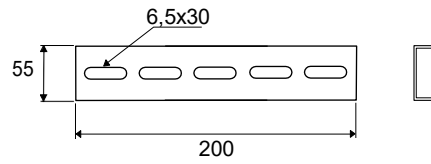

	Electro-galv. Part. No	Weight kg	Hot dip galv. Part. No	Weight kg	Stainl. steel AISI316L Part. No	Weight kg
Joining Fitting B24	11 491 65	0,28	11 492 65	0,29	11 493 65	0,28

Use and installation

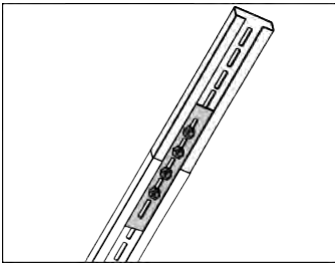

Extension B19 is joined with Joining Fitting B24 and 4 Bolt and Nut B13.

Side support B10

Increases stability of pendant with assymetrical load.

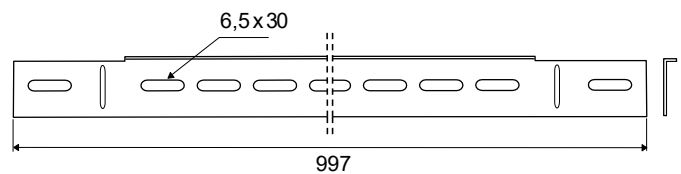

	Electro-galv. Part. No	Weight kg	Hot dip galv. Part. No	Weight kg	Stainl. steel AISI316L Part. No	Weight kg
Side Support B10	11 491 49	0,93	11 492 49	0,93	11 493 49	0,93

Use and installation

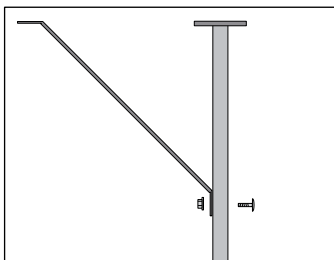

To reduce deflection of long pendants with heavy load. Mounted to Pendant with 1 Bolt and Nut B13.

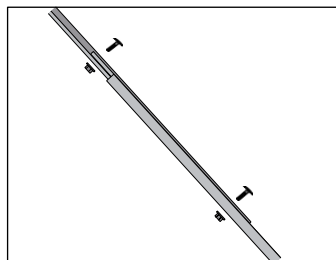

Join 2 Side supports B10 with 2 pcs Bolt and Nut B13 to extend the length.

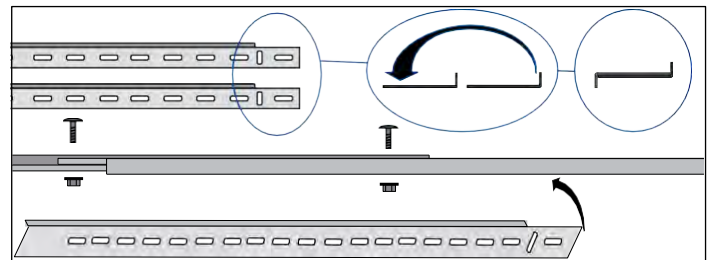



Support Hook B35/120-220

Support Hook B35 for 120-220 mm Wire tray.

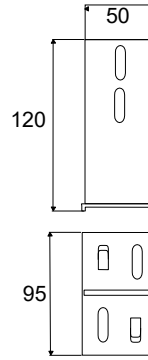

	Electro-galv. Part. No	Weight kg	Hot dip galv. Part. No	Weight kg	Stainl. steel AISI316L Part. No	Weight kg
Support Hook B35/ 120-220	11 491 19	0,30	11 492 19	0,30	11 493 19	0,26

Use and installation

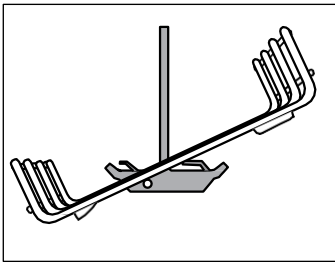

Mounted from below with angled movement.

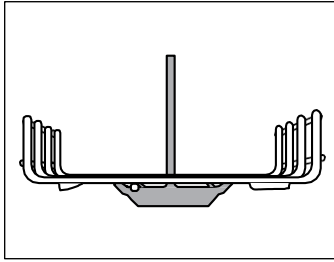

Wire tray is mounted by closing the B35 grips.

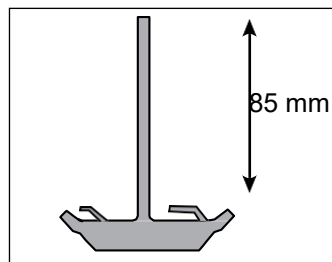

Adjustable 85 mm with Pendant B12L, B12 and Extension B19.

Support Hook B35/320-422

Support Hook for 320-422 mm Wire tray.

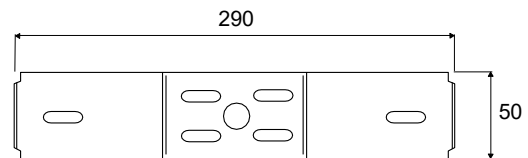

	Electro-galv. Part. No	Weight kg	Hot dip galv. Part. No	Weight kg	Stainl. steel AISI316L Part. No	Weight kg
Support Hook B35/320-422	11 491 20	0,52	11 492 20	0,54	11 493 20	0,48

Use and installation

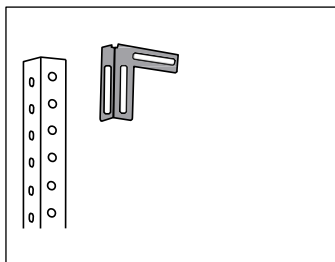

Mounted from below with angled movement and with closing of the B35 grips around the wires.

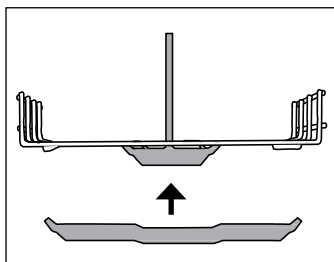

Mount the lower part of the Support Hook with 2 Bolt and Nut B13.

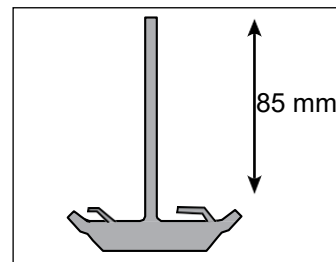

Adjustable 85 mm with Pendant B12L, B12 and Extension B19.

Support Hook B35/422-622

Reinforced support hook for 422-622 mm Wire tray.

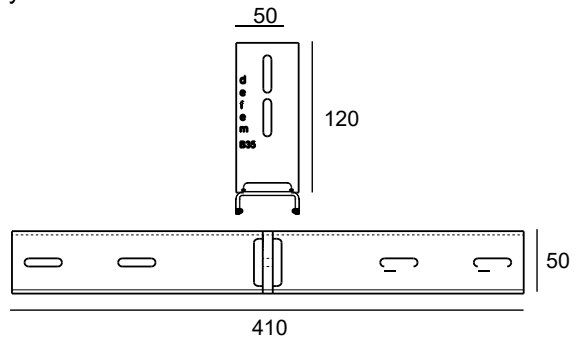
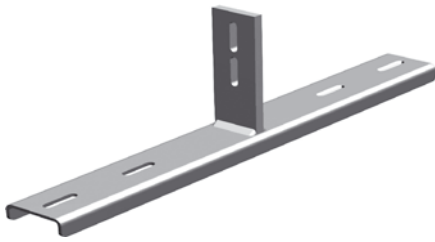

	Electro-galv. Part. No	Weight kg	Hot dip galv. Part. No	Weight kg	Stainl. steel AISI316L Part. No	Weight kg
SupportHook B35/422-622	11491 30	1,05	11492 30	1,14	11493 30	1,03

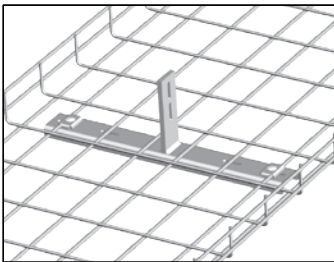

Mounted from below with angled movement and with closing of the B35 grips around the wires.

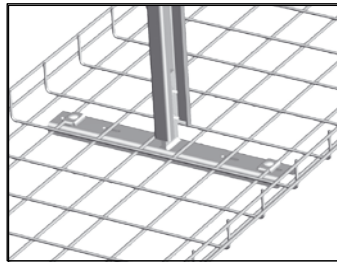

Mount the lower part of the Support Hook with 2 Bolt and Nut B13.

Ceiling Fitting Universal B46

For mounting of Threaded Rod B41 onto ceiling.

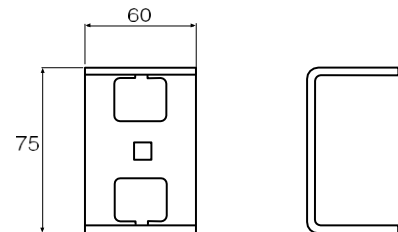

	Electro-galv. Part. No	Weight kg	Stainl. steel AISI316L Part. No	Weight kg
Ceiling Fitting Universal B46	11 49474	0,09	11 495 74	0,09

Use and installation

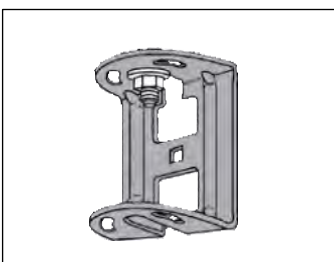

Mount the Ceiling Fitting B46 with Expansion bolt or bolt onto horizontal ceiling.

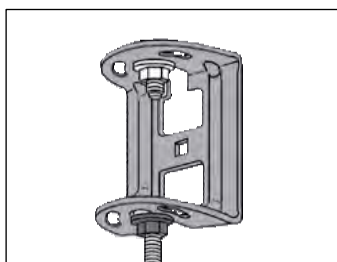

Threaded Rod B41 M8 or M10 is mounted as pendant with 2 Flange Nut B43.

Ceiling Fitting Flexible B47

Adjusts to inclination of ceiling. Delivered complete with *Tensi-lock* Flange Nut.

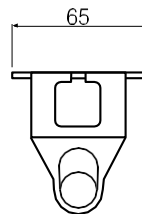
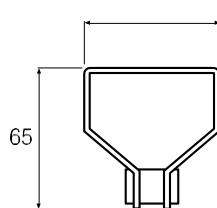

	Electro-galv. Part. No	Weight kg	Stainl. steel AISI316L Part. No	Weight kg
Ceiling Fitting Flexible B47/M8	11 494 75	0,12	11 495 75	0,13
Ceiling Fitting Flexible B47/M10	11 494 76	0,13	11 495 76	0,13

Use and installation

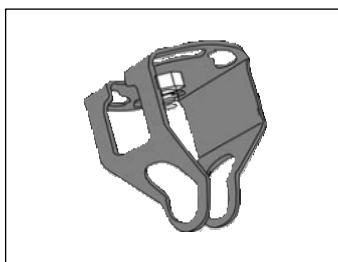

Mount the Ceiling Fitting B47 with Expansion bolt or bolt onto level or sloping ceiling.

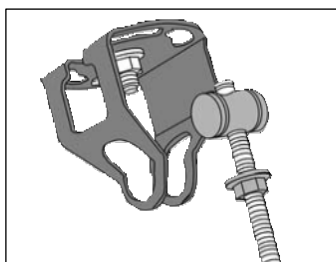

Screw in the yoke and the *Tensi-lock* nut onto the Threaded Rod B41.

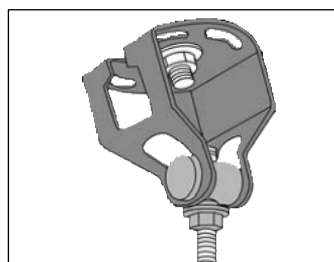

Hook the Threaded Rod onto the B47 and tighten the Nut.

Ceiling Clamp B48

For hole Ø 22 mm. Delivered complete with *Tensi-lock* Nut and washers.

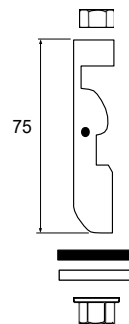

	Electro-galv. Part. No	Weight kg	Stainl. steel AISI316L Part. No	Weight kg
Ceiling Clamp B48/M8	11 494 72	0,06	11 495 72	0,06
Ceiling Clamp B48/M10	11 494 73	0,07	11 495 73	0,07

Use and installation

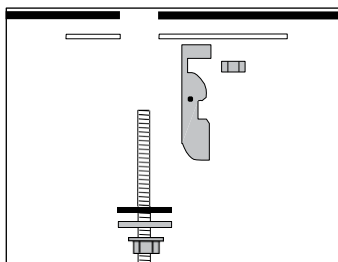

Drill a Ø22 mm hole in the ceiling metal.

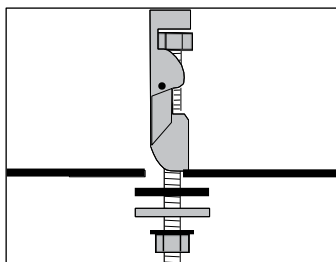

Assemble and mount the Ceiling Clamp according to picture.

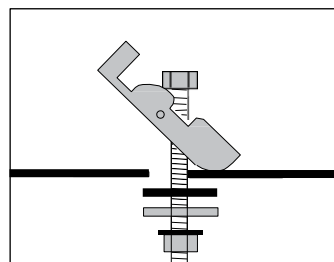

Pull down.

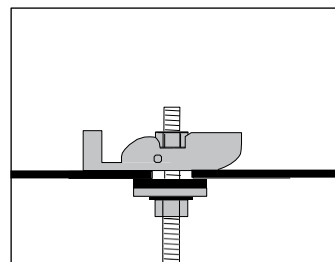

Close with the rod nut.

Threaded Rod B41

Metric standard: 6G.



	Lenght mm	Electro-galv. Part. No	Weight kg	Stainl. steel AISI316L Part. No	Weight kg
Threaded Rod B41M8	1000	11 494 51	0,31	11 495 51	0,32
Threaded Rod B41M8	2000	11 494 52	0,63	11 495 52	0,63
Threaded Rod B41M10	1000	11 494 61	0,49	11 495 61	0,50
Threaded Rod B41M10	2000	11 494 62	0,98	11 495 62	0,99

Use and installation

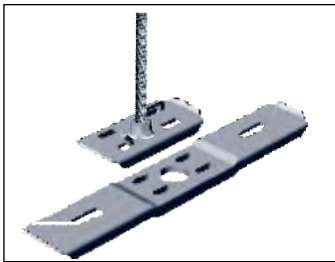

Threaded Rod B41 is mounted onto Support Hook B39 with 2 pcs Flange Nut B43.

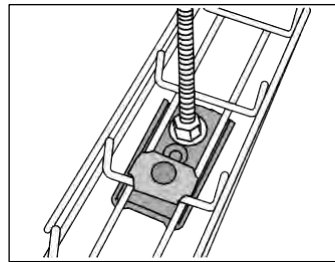

For Wire tray 53 and 75, the Fitting B1 can be used as support hook. Mounting with 1 Fitting B1, 1 Fitting B2, 1 Bolt and Nut B13 and two Flange Nut B43.

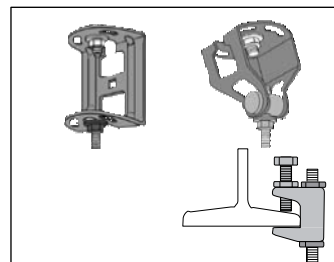

For ceiling mounting, use Ceiling Fittings B46, B47, B48 or B49.

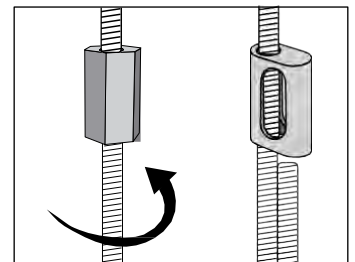

The Threaded Rod is extended by using Distance Nut B42 or Thread Lock B50 as joining fitting.

Flange Nut B43, M8/M10

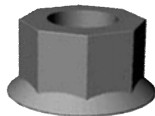

	Number/ package	Electro-galv. Part. No	Weight kg	Stainl. steel AISI316L Part. No	Weight kg
Flange Nut B43/M8	50 st	11 494 05	0,34	11 495 54	0,34
Flange Nut B43/M10	50 st	11 494 64	0,56	11 495 64	0,56

Use and installation

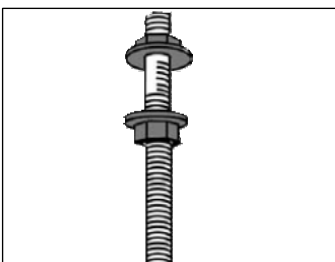

Flange Nut B43 is mounted onto Threaded Rod B41 in order to lock it to the Support Hook and the Ceiling Fittings.

Distance Nut B42

For joining of Threaded Rods.

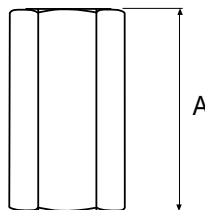

	A mm	Electro-galv. Part. No	Weight kg
Distance Nut B42/M8	30	11 494 55	0,01
Distance Nut B42/M810	40	11 494 65	0,02

Use and installation

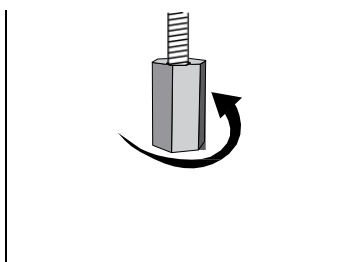

Screw in the Distance Nut on the upper Threaded Rod to the middle.

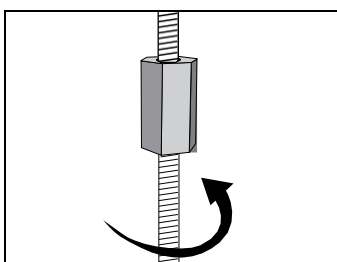

Screw in the lower Threaded Rod into the Distance Nut and tighten.

Thread Lock B50

For joining of Threaded Rods.

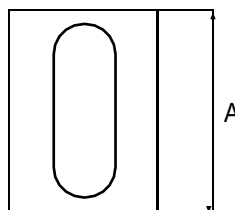

	A mm	Electro-galv. Part. No	Weight kg
Thread Lock B50/M8	35	11 494 56	0,01
Thread Lock B50/M10	35	11 494 66	0,02

Use and installation

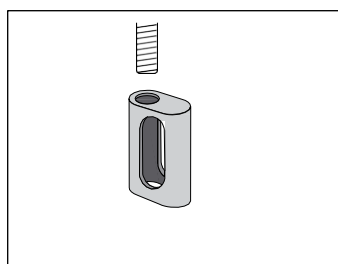

Put the Thread Lock B50 in the desired position onto the upper Rod.

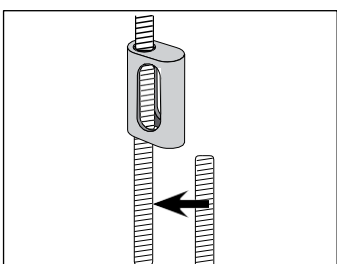

Put the lower Rod in contact with the upper Rod.

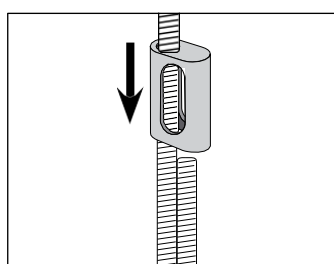

Lower the Thread Lock B50 onto both rods, now in locked position.

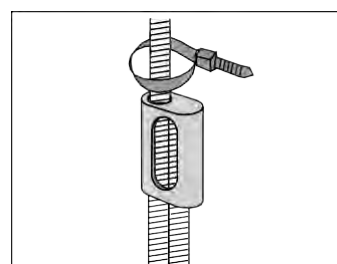

Put a cable stripe above the upper Thread Lock as safety lock.



Beam Clamp B49

For mounting onto beam.

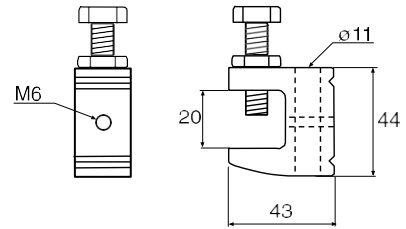

	Electro-galv. Part. No	Weight kg
Beam Clamp B49	11 494 71	0,14

Use and installation

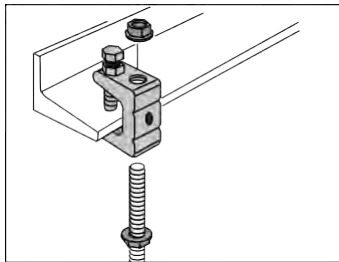

For mounting of Threaded Rod B41 with Flange Nut B43/ M8 – M10.

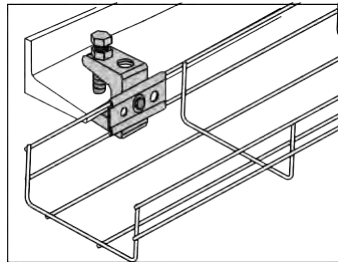

Wire tray 53–120 mm can be mounted directly onto Beam Clamp B48 with Fitting B1 and M6 bolt.

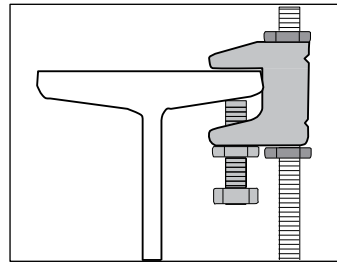

Mount the Beam Clamp with the locking bolt against the sloping side of the beam.

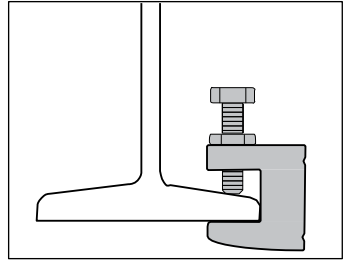

Support Hook B39 120-220 and 320-422

Support Hook for mounting onto Threaded Rod.



Support Hook B39/120-220



Support Hook B39/320-422

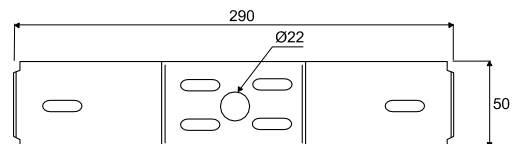
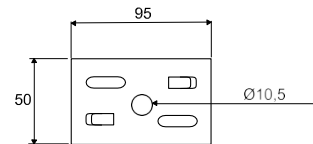

	For tray width mm	Electro-galv. Part. No	Weight kg	Hot dip galv. Part. No	Weight kg	Stainl. steel AISI316L Part. No	Weight kg
Support Hook B39/120-220	120-220	11 491 17	0,08	11 492 17	0,08	11 493 17	0,08
Support Hook B39/320-422	320-422	11 491 18	0,30	11 492 18	0,32	11 493 18	0,30

Use and installation

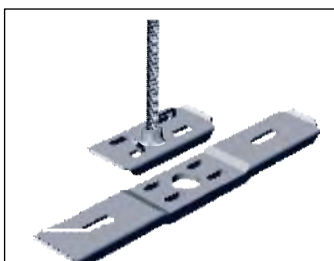

Support Hook B39 is used together with Threaded Rod B41 as pendant. Mounted with 2 Flange Nut B43.

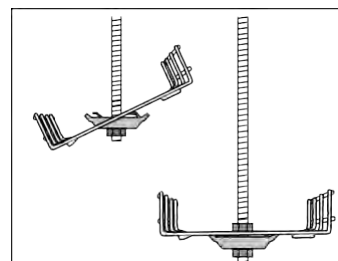

Support Hook B39/120-220. Wire tray is mounted from below angled movement and by closing the grips of the B39 around the wires.

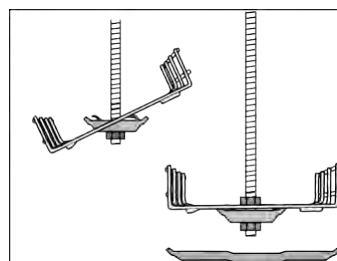

Mount the lower part of B39/320-422, after mounting the Wire Tray, with 2 Bolt and Nut B13.



Accessories Holder B5 Mini

Fits to all Wire Trays.

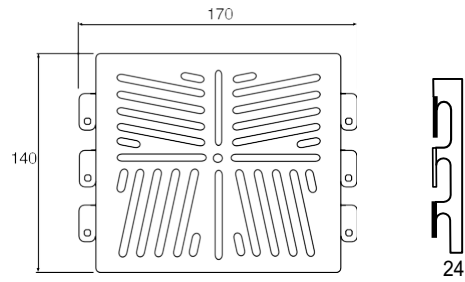

	Electro-galv. Part. No	Weight kg	Hot dip galv. Part. No	Weight kg	Stainl. steel AISI316L Part. No	Weight kg
Accessories Holder B5 Mini	11 491 37	0,20	11 492 37	0,21	11 493 37	0,20

Use and installation

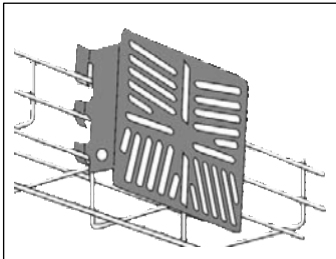

Accessories Holder B5 Mini is easily mounted directly on the side of the wire tray.

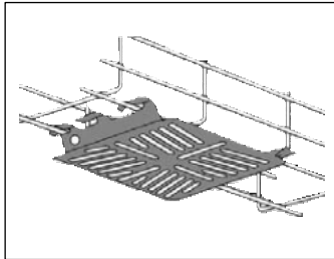

Accessories Holder B5 Mini is mounted equally easy to the bottom of the wire tray.

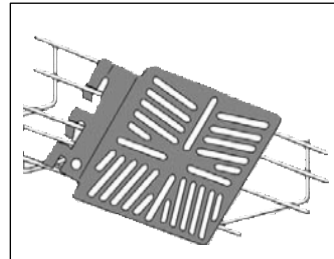

Accessories Holder B5 Mini is also mounted in 45° angle onto the wire tray.

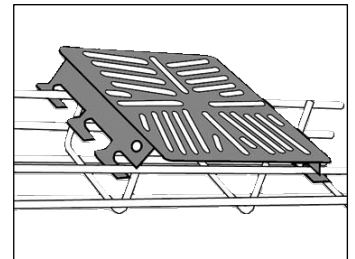

Accessories Holder B5 Mini can also be mounted on top of the 53 and 73 wire trays.

Accessories Holder B5

Fits to all Wire Trays.

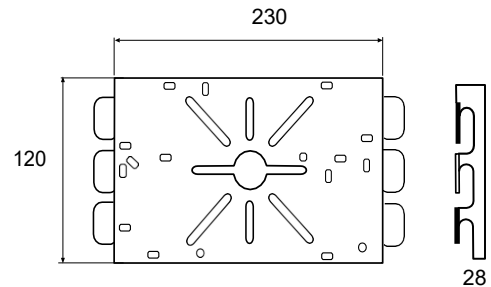
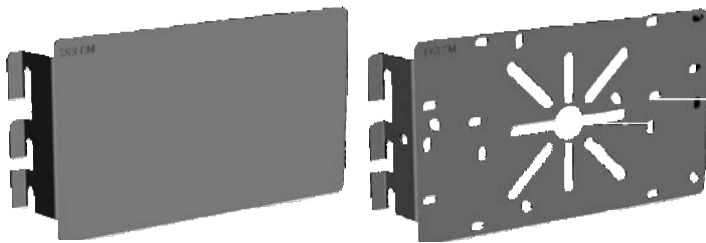

	Electro-galv. Part. No	Weight kg	Hot dip galv. Part. No	Weight kg	Stainl. steel AISI316L Part. No	Weight kg
Accessories Holder B5 without holes	11 491 68	0,46	11 492 68	0,48	11 493 68	0,46
Accessories Holder B5 with holes	11 491 58	0,43	11 492 58	0,44	11 493 58	0,43

Use and installation

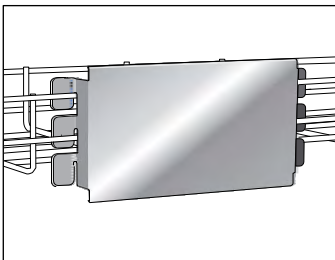

Accessories Holder B5 is easily mounted directly on the side of the wire tray.

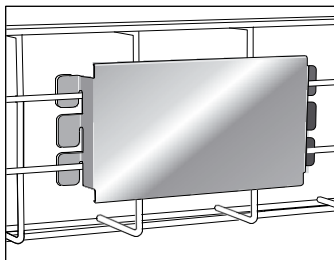

Accessories Holder B5 is mounted equally easy to the bottom of the wire tray.

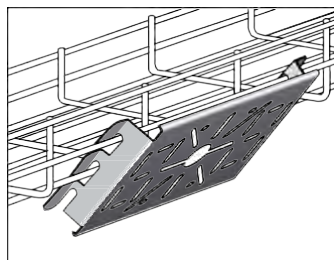

Accessories Holder B5 is also mounted in 45° angle onto the wire tray.

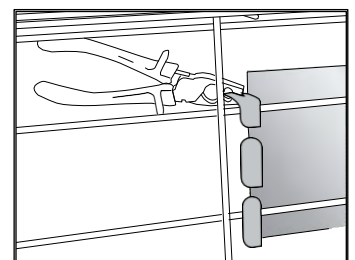

Accessories Holder B5 is tightened to the wire tray by closing the grips around the wires.

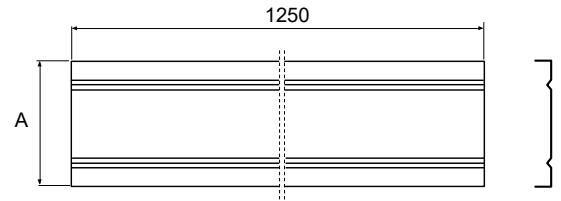
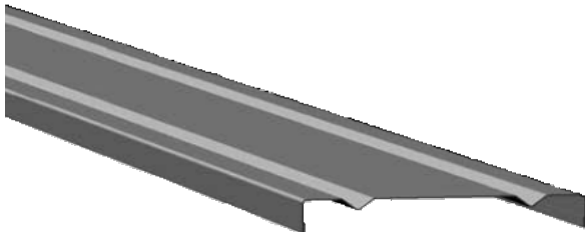

	For tray width mm	A mm	Pre-galv. Part. No	Weight kg	Stainl. steel AISI316L Part. No	Weight kg
Plate Cover B7/75	75	80	11 492 70	0,80	11 493 70	0,87
Plate Cover B7/120	120	125	11 492 71	1,17	11 493 71	1,24
Plate Cover B7/220	220	225	11 492 72	1,74	11 493 72	1,91
Plate Cover B7/320	320	325	11 492 73	2,39	11 493 73	2,53
Plate Cover B7/422	422	425	11 492 74	3,03	11 493 74	3,27

Use and installation

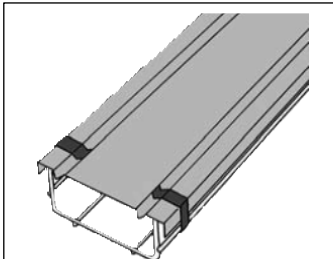

Plate Cover B7 is mounted with Clips B8, 4 pcs/ cover.

Clip B8



	Stainl. steel AISI316L Part. No	Weight kg
Clip B8	11 493 79	0,01

Use and installation

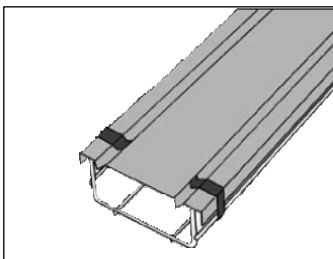
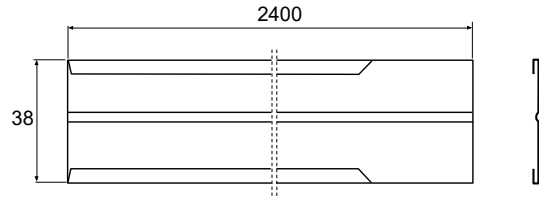
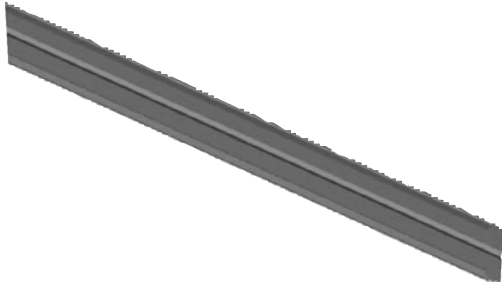

Plate Cover B7 is mounted with Clips B8, 4 pcs/cover.



Separating Plate B36



	Pre-galv. Part. No	Weight kg
Separating Plate B36	11 492 76	0,65

Use and installation

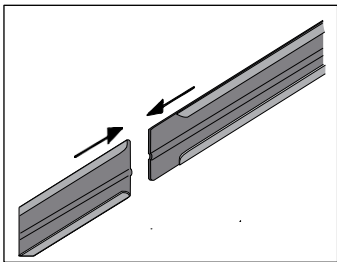

Simple joining by gliding Plates into each other.

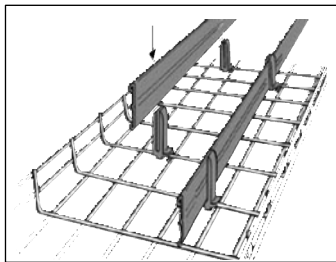
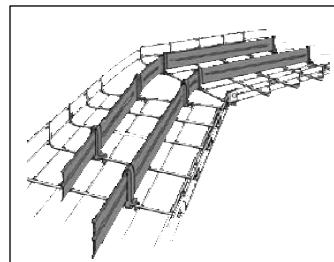

Plate Holder B38 is used for mounting of Separating Plate B36 onto Wire tray.



The Separating Plate B36 can be shaped to follow the horizontal bends of the wire tray.

Plate Holder B38

Used for mounting of Separating Plate B36, 5 pcs/Separating Plate.

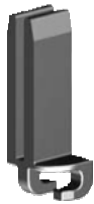

	Electro-galv. Part. No	Weight kg
Plate Holder B38	11 492 89	0,03

Use and installation

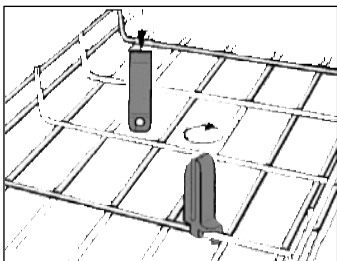

The Plate Holder is easily turned into fixed position on the wire tray.

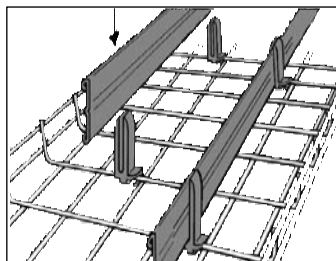

Separating Plate B36 is snapped into the Plate Holder.

Separating Plate B26

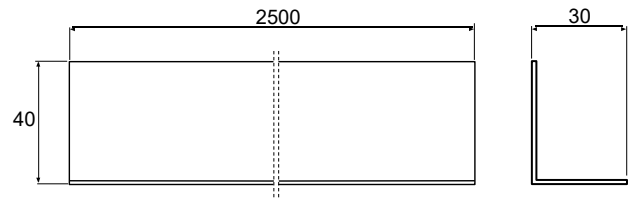
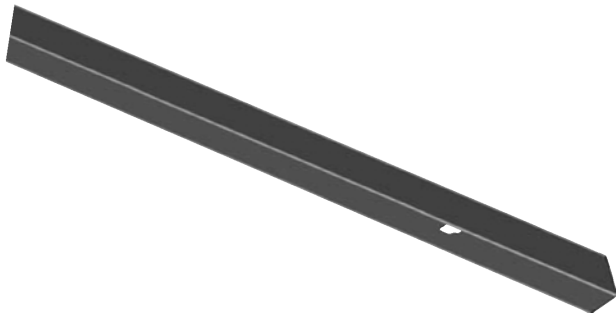

	Pre-galv. Part. No	Weight kg	Stainl. steel AISI316L Part. No	Weight kg
Separating Plate B26	11 492 78	1,14	11 493 78	1,13

Use and installation

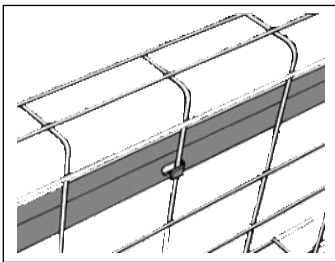

Use the grips of the Separating Plate B26 to attach to the cross wires of the Wire Tray.

Tele-Channel B6

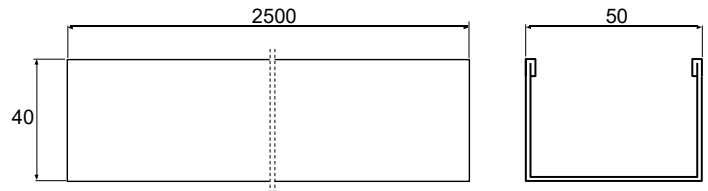
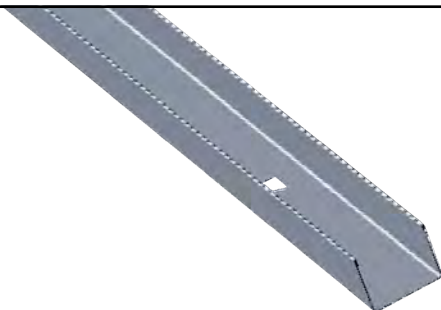

	Pre-galv. Part. No	Weight kg	Stainl. steel AISI316L Part. No	Weight kg
Tele-Channel B6	11 492 47	1,95	11 493 47	2,01

Use and installation

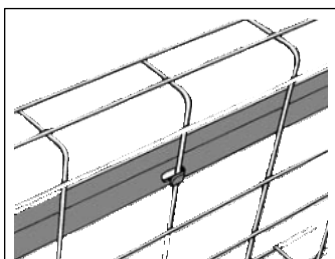

Use the grips of the B6 Tele-channel to attach to the cross wires of the Wire Tray.



Combi Fitting B21

For mounting onto Wibe Cable Ladders.

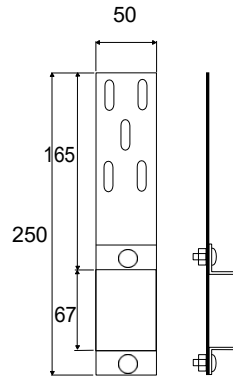

	Electro-galv. Part. No	Weight kg	Hot dip galv. Part. No	Weight kg	Stainl. steel AISI316L Part. No	Weight kg
Combi Fitting B21	11 491 59	0,44	11 492 59	0,48	11 493 59	0,45

Use and installation

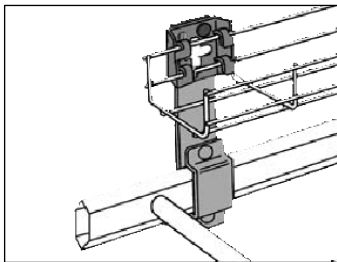

Wire tray 53 and 75 is mounted onto Combi Fitting B21 with Bracket B4 mini Bolt and Nut B13.

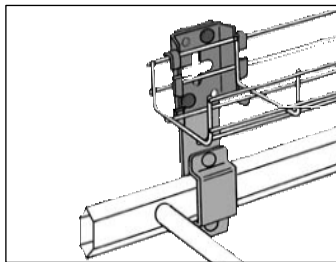

Wire tray 120 is mounted onto Combi Fitting B21 with Bracket B4 Bolt and Nut B13.

Combi Fitting B21 90°

For mounting onto Wibe Cable Ladders.

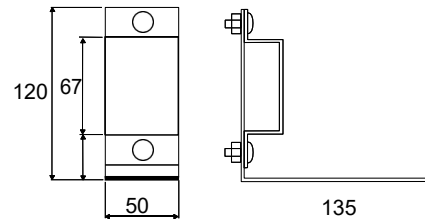
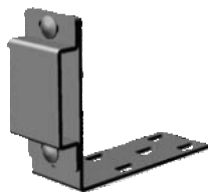

	Electro-galv. Part. No	Weight kg	Hot dip galv. Part. No	Weight kg	Stainl. steel AISI316L Part. No	Weight kg
Combi Fitting B21 90°	11 491 91	0,44	11 492 91	0,46	11 493 91	0,45

Use and installation

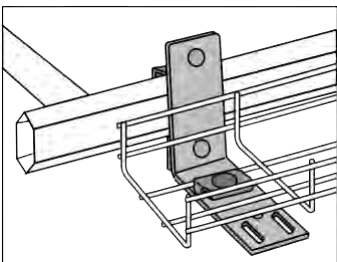

Wire tray 53, 75 and 120 is mounted onto Combi Fitting B21 90° with 1 Fitting B2 1 Bolt and Nut B13.



Mounting coupler B20

Used for joining and mounting of Mini Mesh Wire trays.

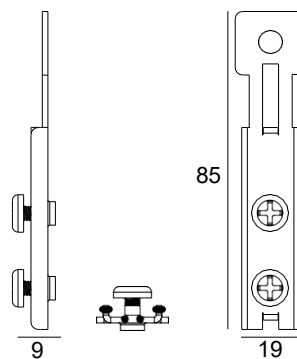
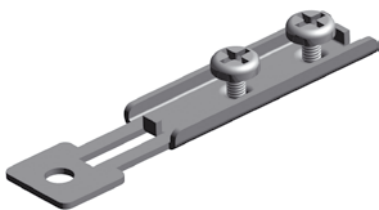

	Electro-galv. Part. No	Weight kg	Hot dip galv. Part. No	Weight kg	Stainl. steel AISI316L Part. No	Weight kg
Mounting coupler B20	11 49131	0,02	11 492 31	0,02	11 493 31	0,02

Use and installation

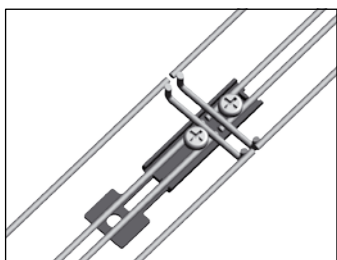

Used for joining of Mini Mesh Trays.

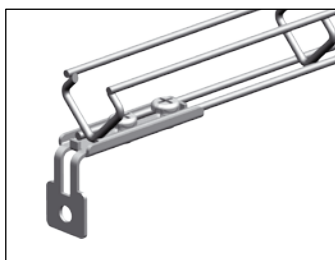

Can be used for mounting of Mini Mesh trays to ceiling, floor and onto wall.

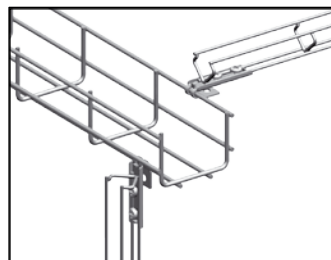

The mounting coupler can be used for vertical and horizontal mounting of Mini Mesh trays onto wire trays and cable ladders.



Support B33

For mounting of all Wire trays on floor, for example under raised floor.

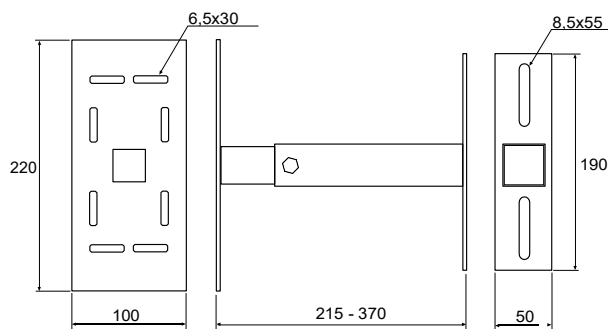

	Electro-galv. Part. No	Weight kg	Hot dip galv. Part. No	Weight kg	Stainl. steel AISI316L Part. No	Weight kg
Support B33	11 491 35	1,69	11 492 35	1,74	11 493 35	1,57

Use and installation

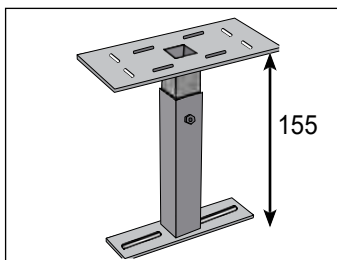

B33 Support is adjustable in height from 215 to 370 mm.

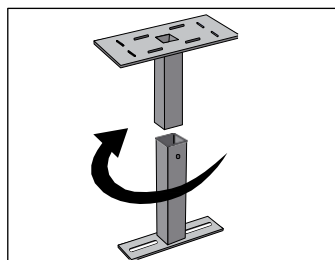

Upper or lower part can be adjusted in 90° angle.

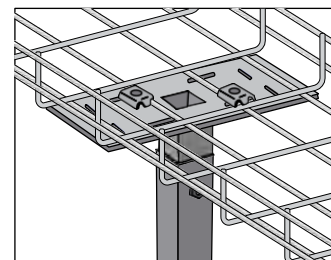

Wire tray is mounted with suitable number of Fitting B2, Bolt and Nut B13.



Conveyor Bracket B17

Universal fitting for mounting of wire trays along conveyor system.

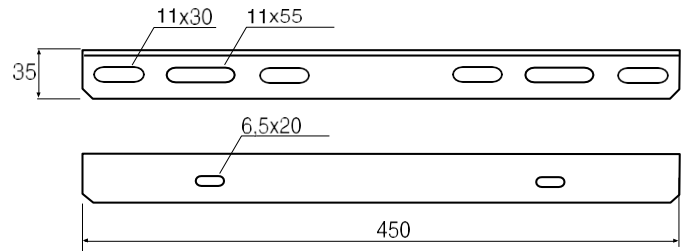
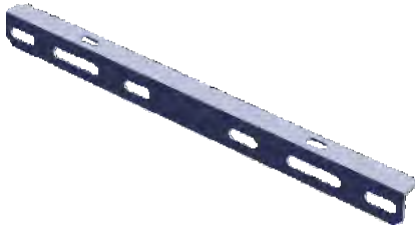

	Electro-galv. Part. No	Weight kg	Hot dip galv. Part. No	Weight kg	Stainl. steel AISI316L Part. No	Weight kg
Conveyor Bracket B17	11 491 92	0,52	11 492 92	0,56	11 493 92	0,55

Use and installation

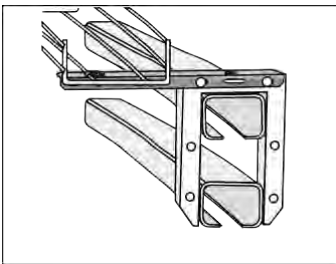

The Wire tray is mounted onto the Conveyor Bracket with
1 Fitting B2.
1 Bolt and Nut B13.

Earth Connection Clamp B18

For mounting of earth cable onto chosen wire in the Wire tray.



Weight
kg

	Nickel coated brass Part. No	Weight kg
Earth Connection Clamp B18	11 491 80	0,02

Use and installation

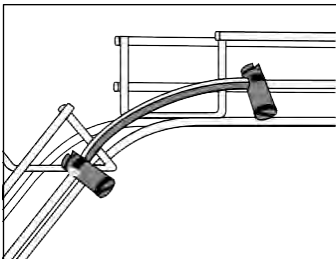

Earth connection clamp B18 is mounted to connect earth cable to wiretray.



Safety Cap B32

Halogen free and flame proof plastic material.

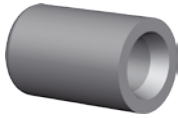

Safety Cap B32/3



Safety Cap B32/4/5/6

	For wire diameter mm	Number/ package	Plastic Part. No	Weight kg
Safety Cap B32/3	3	100	11 493 89	0,04
Safety Cap B32/4	4	100	11 493 88	0,04
Safety Cap B32/5	5	100	11 493 66	0,03
Safety Cap B32/6	6	100	11 493 67	0,03

Use and installation

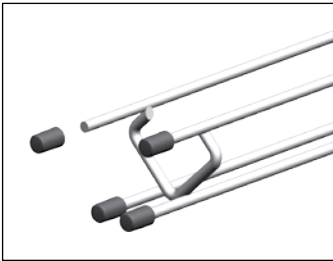

Mount Safety Caps onto wires sticking out.

Mounting Spacer B22

Plastic Spacer that fits all Mini Mesh dimensions.
Easy to mount, just snap the spacer onto the bottom wires.

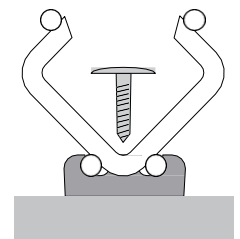
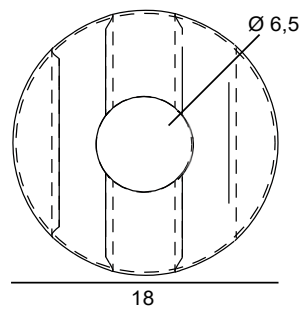

	For wire diameter mm	Grey Plastic Part. No	Weight kg
Mounting Spacer B22	3	11 495 23	0,1

Use and installation

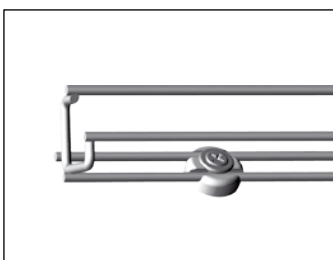

Front view of Mounting Spacer B22 attached to Mini Mesh.

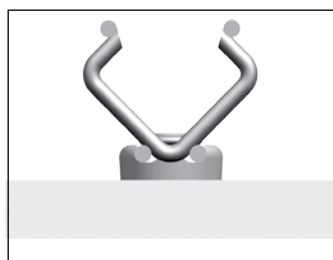

Side view of Mounting Spacer B22 attached to Mini Mesh-D.

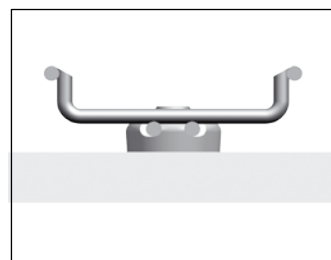

Side view of Mounting Spacer B22 attached to Mini Mesh-U.

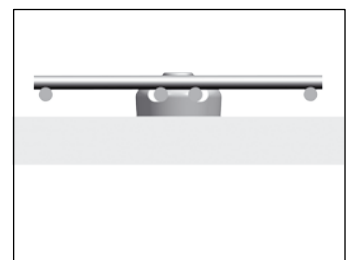

Side view of Mounting Spacer B22 attached to Mini Mesh-I.



Bend Plate B31

For smooth cable bend at change of level.

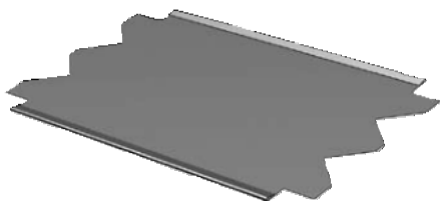

	For tray width mm	A mm	Aluminium Part. No	Weight kg
Bend Plate B31/120	120	90	11 492 26	0,04
Bend Plate B31/220	220	190	11 492 27	0,09
Bend Plate B31/320	320	290	11 492 28	0,13
Bend Plate B31/422	422	390	11 492 29	0,17

Use and installation

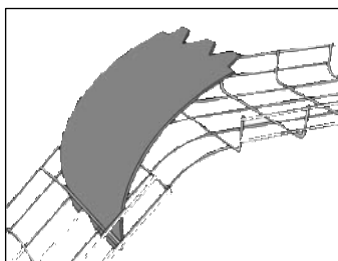

Attach the Bend Plate ends into the lower part of the Wire tray.

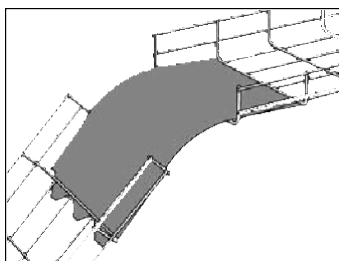

Attach the Bend Plate into the upper part of the Wire tray.

Side Radius Limiter B11

Used for limiting side bend radius of any cable type.

B11/5 for wire trays 75x5-320 mm.

B11/6 for wire trays 422-622 mm.

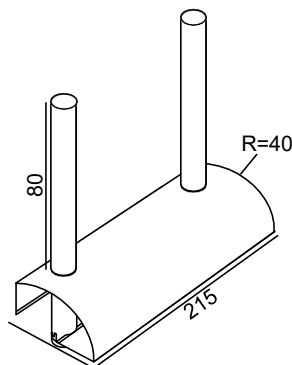
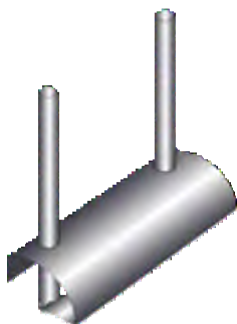

	Pre-galv. Part. No	Weight kg
Side Radius Limiter B11/5	11 494 38	0,24
Side Radius Limiter B11/6	11 494 39	0,24

Use and installation

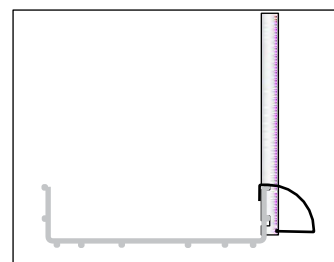
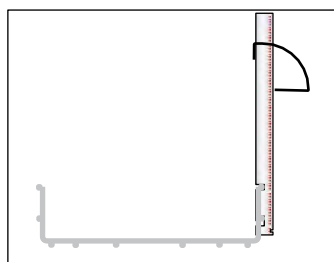
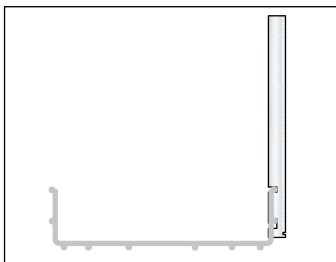
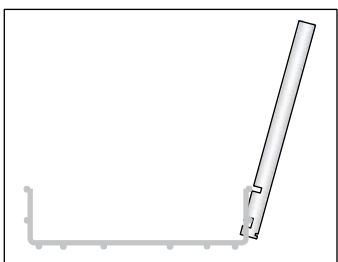



Radius Limiter B34

Limits the bend radius for sensitive cables.

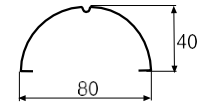
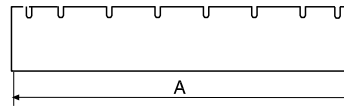
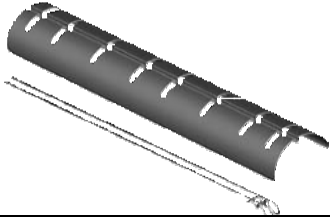

	For tray widths mm	A mm	Pre-galv. Part. No	Weight kg	Stainl./AISI316L* Part. No	Weight kg
Radius Limiter B34/75	75	75	11 494 37	0,08	11 495 37	0,09
Radius Limiter B34/120	120	115	11 494 31	0,10	11 495 31	0,11
Radius Limiter B34/220	220	215	11 494 32	0,21	11 495 32	0,22
Radius Limiter B34/320	320	315	11 494 33	0,32	11 495 33	0,33
Radius Limiter B34/422	422	415	11 494 34	0,43	11 495 34	0,45
Radius Limiter B34/522	522	515	11 494 35	0,55	11 495 35	0,58
Radius Limiter B34/622	622	615	11 494 36	0,65	11 495 36	0,68

*not a stock item

Radius Limiter B67

Limits the bend radius and gives protection at side position. Lacquered version can be offered.
Cover B68 is used for protection of cables < 2 mm.

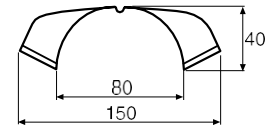
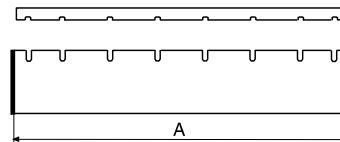

	For tray widths mm	A mm	Pre-galv. Part. No	Weight kg
Radius Limiter B67/75	75	75	11 494 42	0,13
Cover B68/75	75	60	11 494 82	0,01
Radius Limiter B67/120	120	115	11 494 43	0,18
Cover B68/120	120	102	11 494 83	0,02
Radius Limiter B67/220	220	215	11 494 44	0,30
Cover B68/220	220	202	11 494 84	0,04
Radius Limiter B67/320	320	315	11 494 45	0,42
Cover B68/320	320	302	11 494 85	0,06
Radius Limiter B67/422	422	415	11 494 46	0,53
Cover B68/422	422	402	11 494 86	0,08
Radius Limiter B67/522	522	515	11 494 47	0,65
Cover B68/522	522	502	11 494 87	0,10
Radius Limiter B67/622	622	615	11 494 48	0,77
Cover B68/622	622	602	11 494 88	0,12

Use and installation

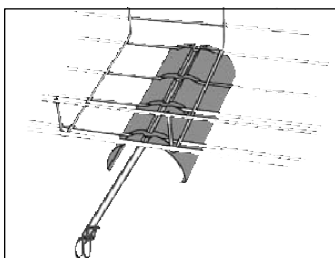

The radius limiter is mounted from below with the locking stick.



Cable Roller B25

Facilitates the pulling of cables into the wire trays.

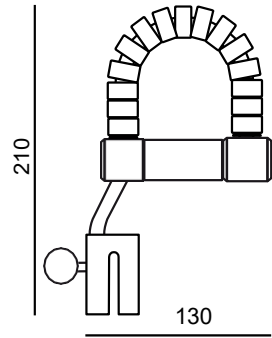

	Stainl. steel AISI316L/plastic Part. No	Weight kg
Cable Roller B25	16 539 55	0,35

Use and installation

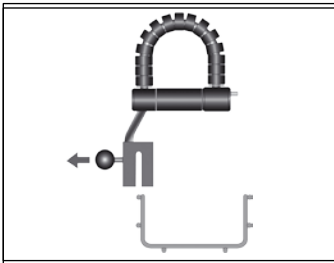

Pull the black knob outwards, place the cable roller onto the wire tray.

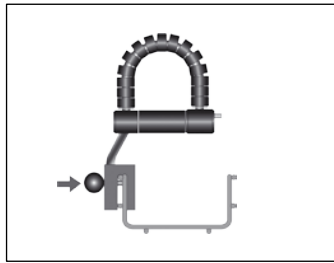

Release the black knob and the cable roller is securely mounted on the wire tray.

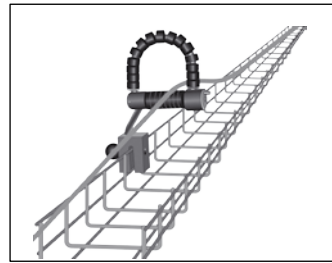

Simply pull the cable through the cable roller to the desired distance.

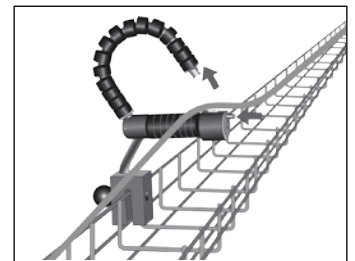

Push the small metal button to open the cable roller and place the cable in the tray.

AS-I Clips B14

Oil- and UV-resistant plastics.



	For wire diameter mm	Number/ package	Plastic Part. No	Weight kg
AS-I clips Plastic, blue	4	100	11 495 20	0,10
AS-I clips Plastic, grey	5	100	11 495 21	0,10

Use and installation

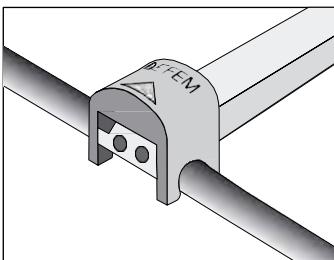

For fixing of AS-I cable. Blue for 4 mm wire, grey for 5 mm wire.

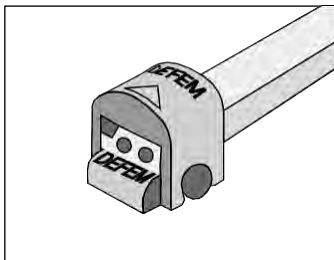

Grey clips are also used for mounting onto Fixing Plate B15.



Fixing Plate B15

Oil- and UV- resistant plastics.



	Number/ package	Plastic Part. No	Weight kg
Fixing Plate B15, grey	100	11 495 22	0,07

Use and installation

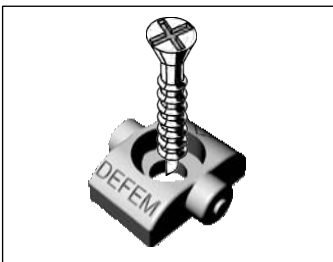

For mounting of cable or hose onto, for example, machines. Mounted with suitable screw.

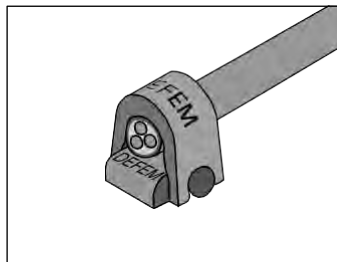

The cable is mounted with Cable Clips B16 onto Fixing Plate B15.

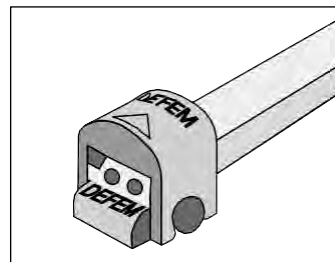

The AS-I cable is mounted with B14 AS-I Clip onto Fixing Plate B15.

Cable Clips B16

Oil and UV resistant plastics.

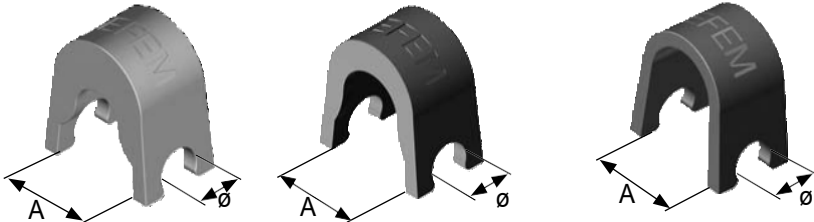

	A	ø	Number/ package	Plastic Part. No	Weight kg
Cable Clips B16, gray	6	5	100	11 495 25	0,11
Cable Clips B16, black	8	5	100	11 495 26	0,10
Cable Clips B16, white	10	5	100	11 495 27	0,09

Use and installation

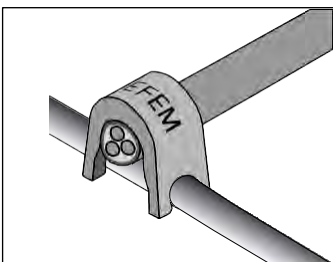

For mounting of cable or hose, Ø 6, 8 or 10 mm, onto 5 mm tray wire.

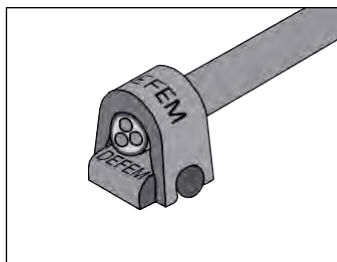

Also used for mounting of cable or hose onto Fixing Plate B15.



Velcro B51

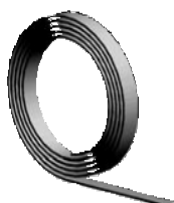

	Colour	Width mm	Lenght m	Part. No	Weight kg
Velcro B51/10	Black	10	22,8	15 186 50	0,16
Velcro B51/20	Black	20	22,8	15 186 51	0,32

Use and installation

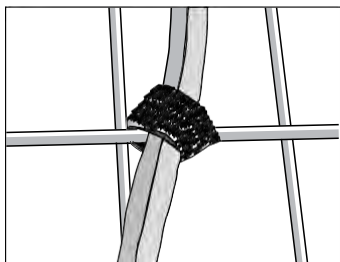

For attaching bundles of cables onto wire tray.

Certificate Equipotential Bonding

Certificate and mounting instructions for Wire Tray DEFEM® as conductor of equipotential bonding.



		Part. No	Weight kg
Certifikat Potentialutjämning	Swedish	29 70 40	0,01
Certificate Equipotential Bonding	English	29 71 40	0,01
Zertifikat Potentialausgleich	German	29 72 40	0,01



Marking Clip B44

Flame resistant plastics.

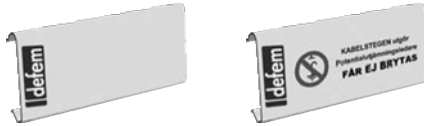

	Language	Plastic Part. No	Weight kg
Marking Clip B44		11 494 27	0,01
Marking Clip B44/Potentialutjämning	Swedish	11 494 28	0,01
Marking Clip B44/Equipotential Bonding	English	11 494 29	0,01
Marking Clip B44/Potentialausgleich	German	11 494 30	0,01

Use and installation

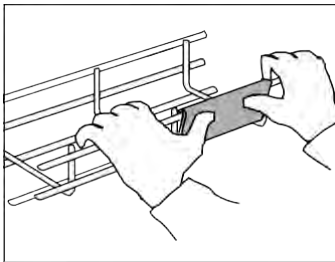

The Marking Clip is snapped onto the two side wires.

Identification Tag B40

Fits to wire Ø 5mm. Can be offered with special text.
Made of extruded plastics.



	Words	Plast Part. No	Weight kg
Identification Tag B40/Opto	Opto	11 494 20	0,01
Identification Tag B40/Coax	Coax	11 494 21	0,01
Identification Tag B40/Pair	Pair	11 494 22	0,01
Identification Tag B40/Neutral	Neutral	11 494 23	0,01
Identification Tag B40/Pow	Pow	11 494 24	0,01

Use and installation

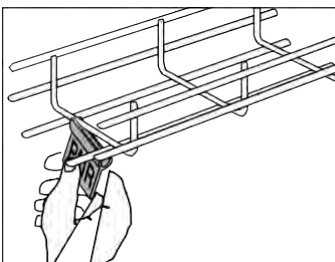

The Identification Tag is snapped onto the wire tray.

Bolt Cutter B28

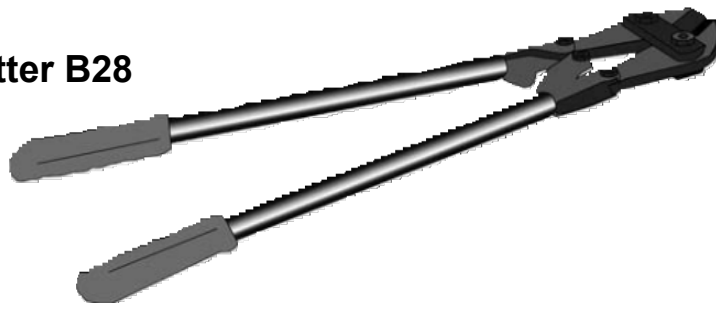

	Part. No	Weight kg
Bolt Cutter B28	16 239 98	2,72

10 mm Spanner B45

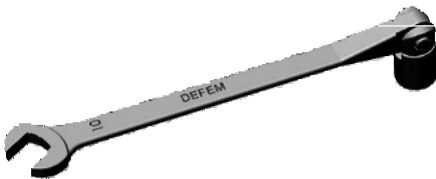

	Chrome Vanadium Part. No	Weight kg
10mm Spanner B45	16 222 00	0,07

